



Website: www.TBEI.com
E-mail: sales@TBEI.com
Phone: 1-800-869-9162 Rugby
1-800-255-4345 DuraClass
1-800-533-0494 Crysteel



ELIMINATOR

Operation Manual

To Be Filled In By Installer

Body Serial #: _____

In Service Date: _____

Dealer: _____

Address: _____

City, State, ZIP: _____

Dealer Phone Number: _____

Contents

Warnings.....	3
Operation.....	5
Decal Location.....	10
Maintenance.....	13
Hoist Application Reference Guide.....	14
Installation.....	15
Assembly Diagram.....	16

Warnings

WARNING: Installing or operating this hoist without first understanding the proper installation and operation procedures can lead to serious injury or death. **Always** read and understand fully all installation and operation manuals before installing or operating this equipment.

WARNING: Welding, oxy-fuel cutting, or grinding sparks can cause fuel to ignite which in turn can lead to injury or death. **Always** take adequate steps to avoid ignition of fuel from fuel tanks when welding, grinding, or oxy-fuel cutting during equipment installation.

WARNING: Heat from the truck's exhaust system can cause hydraulic component failure and may lead to a fire which could cause injury or death. **Always** install equipment in locations where heat from the exhaust system will not damage any hydraulic component.

WARNING: Being under a raised body can result in serious injury or death should the body inadvertently descend. **Never** position yourself or allow others to position themselves under a **loaded** body. **Always** prop the **unloaded** body up using the body prop or body props supplied. **Remember** body props are to be used only on an **unloaded** body.

WARNING: Malfunctioning equipment can cause property damage, injury or death. **Always** have faulty equipment repaired before continuing its use. If required, consult the manufacturer.

WARNING: Overloading of a truck can cause truck component damage or an accident which may cause injury or death. **Never** exceed the gross vehicle weight (GVW) or the gross axle weight (GAW) rating of your vehicle or trailer.

WARNING: The inadvertent shorting of the truck's electrical supply can cause a fire or equipment damage that could lead to injury or death. **Always** disconnect the vehicle battery prior to installing, servicing or repairing the pump.

WARNING: Connecting the hoist to a hydraulic system with more pressure (psi) or flow (gpm) than is recommended by the hoist manufacturer can cause the hoist to fail during the dumping of a load. This could lead to damage, serious injury, or death. **Be sure** you have the correct pressure and flow. Consult the manufacturer if you do not know the recommended pressure and flow.

WARNING: Adjusting the hydraulic pressure to more than the recommended setting may cause the hoist to fail during the dumping of a load. This could cause damage, serious injury, or death. **Never** adjust the pressure on your own. Consult the manufacturer if the hydraulic pressure is in question. Have only a qualified person set the hydraulic pressure. **Never** adjust the pressure to more than the recommended amount.

WARNING: Fluid under pressure can pierce the skin and enter bloodstream, causing serious injury or death. **Always** wear eye protection and protective clothing when working around hydraulic systems.

WARNING: Damage to brake lines during equipment installation, or installing bolts or equipment in such a way that the line will rub and become damaged can lead to brake failure which can cause an accident and can lead to severe injury or death. **Always** take adequate steps to prevent brake line damage during installation and isolate brake lines from installed equipment.

WARNING: Never install a cable on a truck while the body is raised without first blocking, bracing, or propping the body up to prevent the body from inadvertently falling when the control valve lever is moved. A falling body will result in serious injury or death if the control valve lever is moved while someone is under the non-supported body.

WARNING: Do not raise or drive a raised body against a power line. Bring body in contact with a power line or power source will result in serious injury or death by electrocution.

WARNING: Do not raise or drive a raised body against another object. Doing so could result in equipment damage or property damage, bodily injury or death.

WARNING: Do not dump while on uneven ground or if vehicle is in an uneven position from side to side. Dumping unevenly can cause vehicle to overturn and cause equipment or property damage, personal injury, or death.

WARNING: Stay clear of dump body when dumping. Moving vehicle parts or the moving load could cause injury or death.

WARNING: Check load making sure that rocks or any other object will not spill out of vehicle while transporting load. Falling objects can cause equipment damage or property damage, bodily injury or death.

WARNING: Make sure all doors are closed and latched before moving vehicle. Swinging doors or falling objects can cause equipment or property damage, bodily injury or death.

Operation

IMPORTANT: There are two ways to open the tailgate on your dump body. One way is to unlatch the bottom of the tailgate, allowing the tailgate to pivot at the tailgate top (see Figure 1). For the purposes of this manual, opening the tailgate in this manner will be referred to as *opening the tailgate bottom up*.

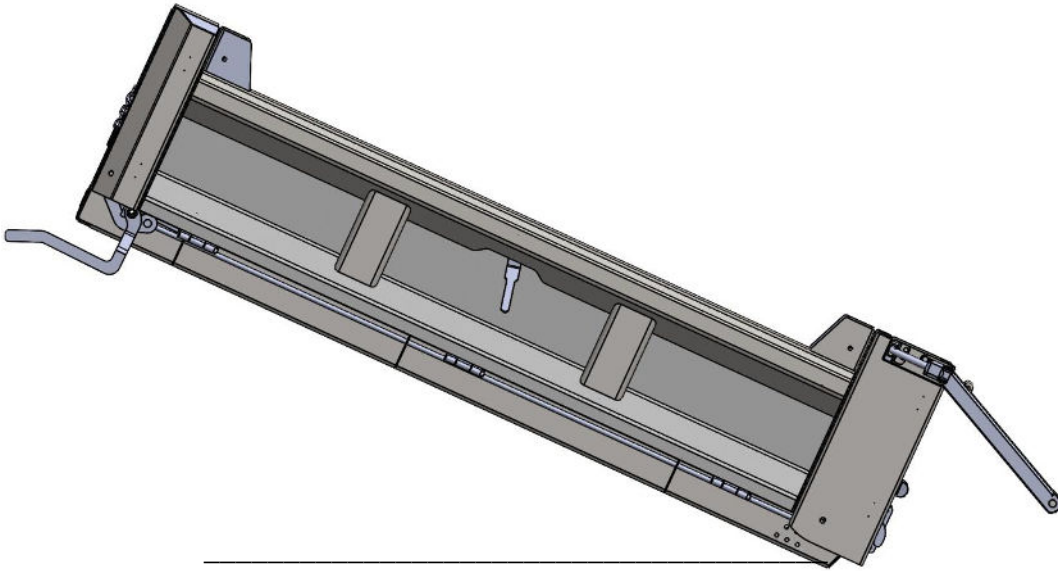

FIGURE 1
OPENING THE TAILGATE BOTTOM UP

The second way the tailgate can be opened is to unlatch the top of the tailgate, allowing the tailgate to pivot at the tailgate bottom (see Figure 2). Again, for the purposes of this manual, opening the tailgate in this manner will be referred to as *opening the tailgate top down*.

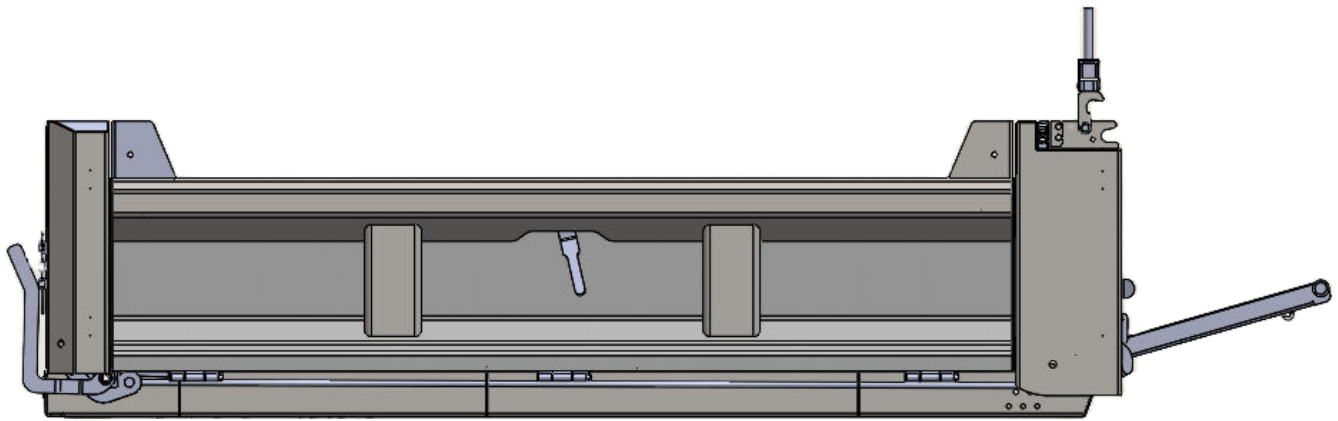

FIGURE 2
OPENING THE TAILGATE TOP DOWN

OPENING AND CLOSING THE TAILGATE TOP DOWN:

1. Open the tailgate latch on one side of the dump body by:
 - Rotate the handle rearward until the handle points straight back
 - Rotate the handle upwards and open as shown in Figure 3.

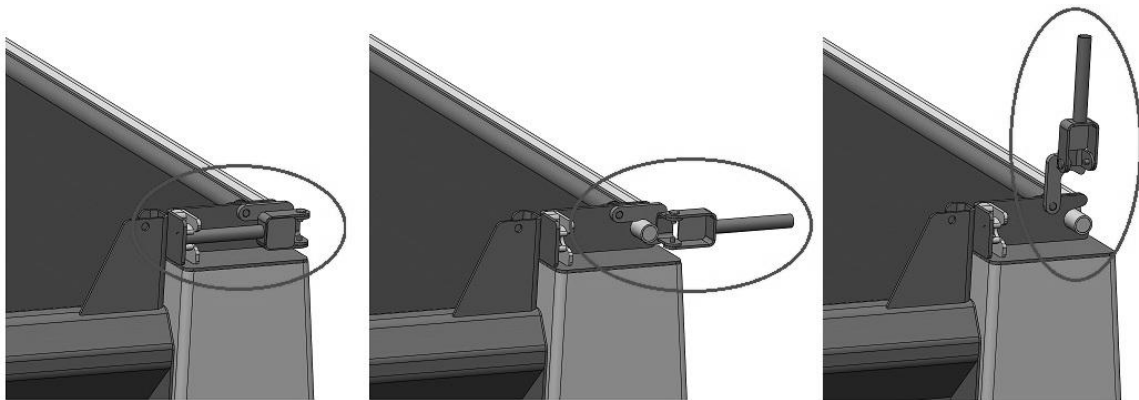

FIGURE 3
OPENING TAILGATE FROM TOP DOWN POSITION

2. Repeat Step #1 for the remaining top tailgate latch located on the other side of the dump body while keeping tailgate secure in the closed position.
3. Rotate the top of the tailgate down. The tailgate will rotate 180° from the closed position.

CAUTION: Raising the dump body to dump a load with the tailgate opened top down can cause damage to the tailgate or the truck if the tailgate strikes a trailer hitch or some other object below the tailgate while dumping.

4. The amount the tailgate will open top down can be limited by using the tailgate chains. In limiting the amount the tailgate opens top down, a chain on each side of the tailgate is run directly to its respective chain slot located on the rear corner posts as shown in Figure 4.

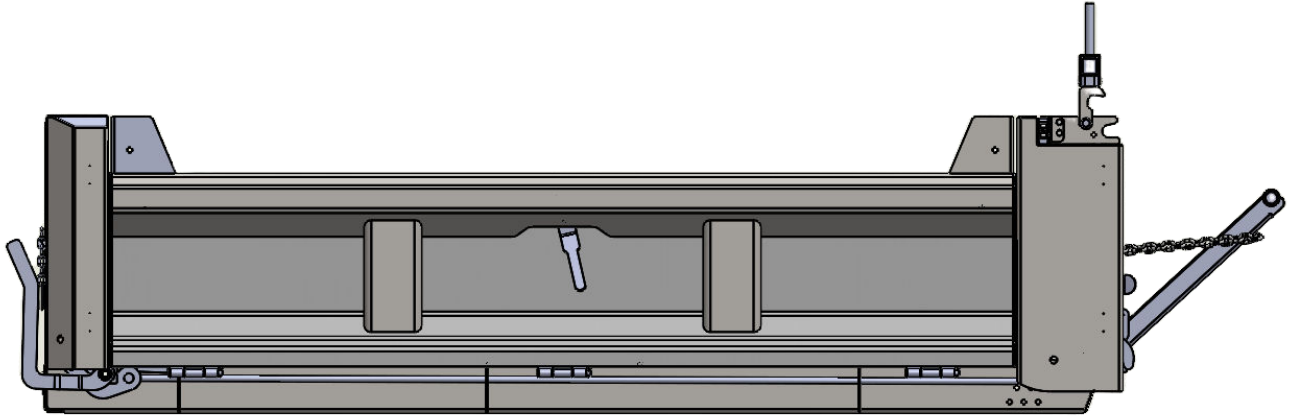

FIGURE 4
LIMITING TOP DOWN OPENING OF TAILGATE WITH CHAIN

WARNING: Failure to latch the tailgate bottom while using or opening the tailgate from the top down will result in the tailgate falling which could result in serious injury. Latch the tailgate bottom before using or opening the tailgate from the top down.

WARNING: Failure to support the tailgate top while opening the tailgate from the top down will result in the tailgate rotating open uncontrollably and could result in serious injury. Support the tailgate at the very top while opening the tailgate from the top down.

WARNING: Failure to keep extremities away from chains and other pinch points while opening the tailgate from the top down could result in serious injury. When opening the tailgate from the top down, hold the tailgate only at the very top away from chains and other pinch points.

5. To close the tailgate, rotate the top of the tailgate up.
6. Close one top tailgate latch first, then the other by:
 - Rotating the handle downward to the closed position.
 - Rotate the handle forward until the handle points straight forward.

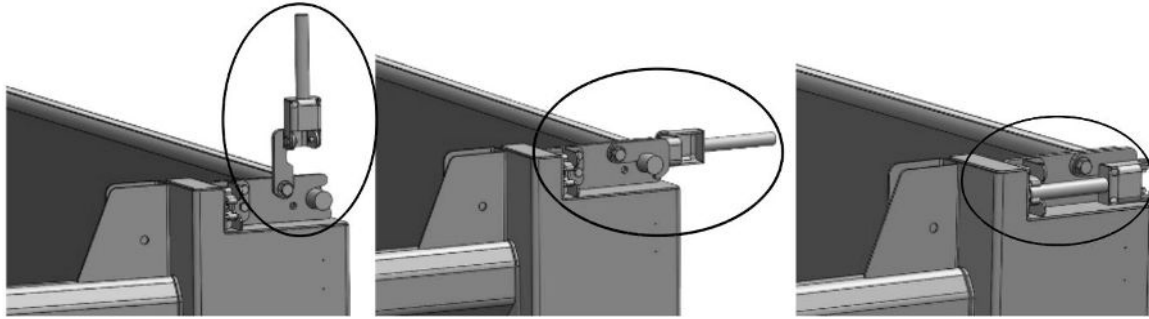

FIGURE 5
CLOSING THE TAILGATE FROM THE TOP-DOWN POSITION

OPENING AND CLOSING THE TAILGATE BOTTOM UP:

1. The tailgate is opened bottom up by using a lever located at the front driver side of the dump body. Begin by removing the safety chain ring from the handle.
2. Rotate the handle down to release the tailgate bottom as shown in Figure 6.

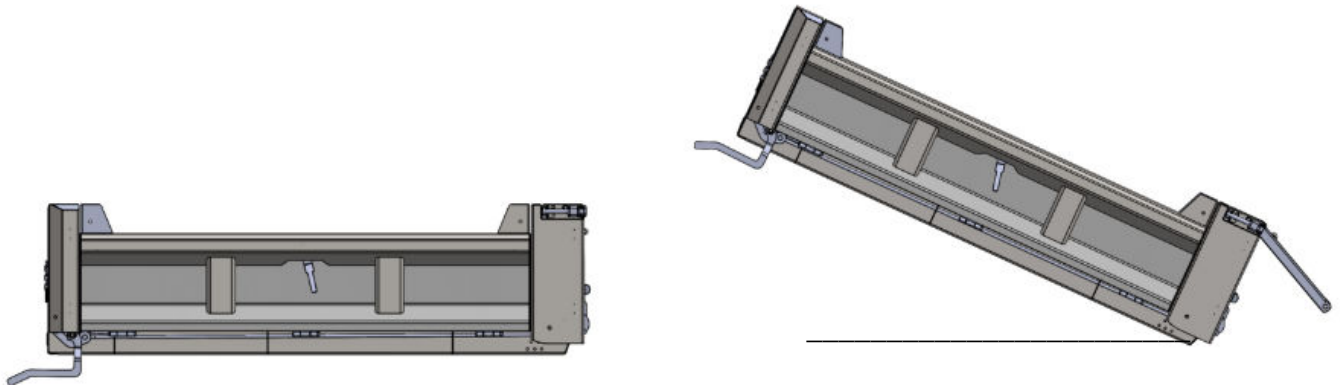

FIGURE 6
OPENING THE TAILGATE BOTTOM UP

WARNING: Standing next to the rear of the dump body when tailgate is opened bottom up can cause the tailgate to strike you, which may cause serious injury. Stay clear of dump body while dumping.

3. The amount the tailgate will open bottom up can be limited by using the tailgate chains. In limiting the amount the tailgate opens bottom up, a chain on each side of the tailgate is run first through its respective tailgate retaining angle and then to its respective chain clot located on the rear corner post as shown in Figure 7.

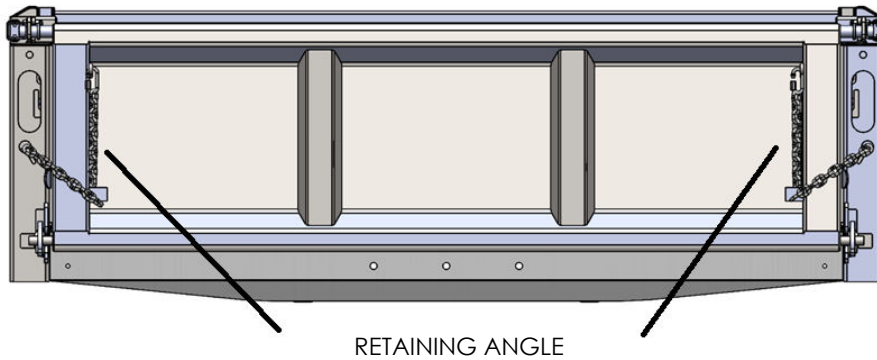

FIGURE 7
LIMITING BOTTOM UP OPENING OF TAILGATE WITH CHAIN

4. To close the tailgate, first lower the dump body.

NOTE: To raise and lower the dump body, refer to the operation instructions for your particular hoist model.

5. Rotate the front lever handle up to latch tailgate bottom.
6. Secure handle by repositioning chain removed in Step #1.

Decal Location

SAFETY DECALS:

One 1654038 (009125) warning decal is supplied with each dump body. This decal must be positioned as shown in Figure 8.

Two 1654043 (009130) warning decals are supplied with each dump body. These decals must be positioned as shown in Figure 8.

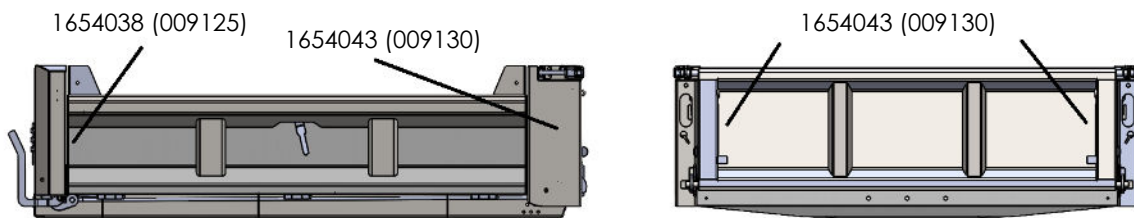



FIGURE 8
DECAL LOCATION

NOTE: Locate the two 1654043(009130) decals on the tailgate as shown or use the alternate location shown (locating one decal on the side of each corner post).

WARNING: Missing or damaged decals can lead to accidents which may cause serious injury or death. If any decals are missing or damaged, they must be replaced.

To obtain replacement decals, contact your local Rugby dealer or contact:

Rugby Manufacturing Co.
Industrial Park
515 1st Street NE
Rugby, ND 58368

 <p>1654038(00 9125)</p>	<p>⚠ WARNING</p> <p>Stay clear of body while dumping.</p> <p>Failure to do so could result in serious injury or death.</p> <p><i>Rugby</i></p>
---	---

WARNING

Failure to support the tailgate top while opening the tailgate from the top down will result in the tailgate rotating open uncontrollably and could result in serious injury. Support the tailgate at the very top while opening the tailgate from the top down.

Failure to keep extremities away from chains and other pinch points while opening the tailgate from the top down could result in serious injury. When opening the tailgate from the top down hold the tailgate only at the very top away from chains and other pinch points.

Failure to latch the tailgate bottom while using or opening the tailgate from the top down will result in the tailgate falling which could result in serious injury. Latch the tailgate bottom before using or opening the tailgate from the top down.

1654043 (009130)

MANUFACTURING CO.

Maintenance

Refer to Figure 9 for grease zerk locations. All grease fittings should be greased periodically or every time the truck is greased.

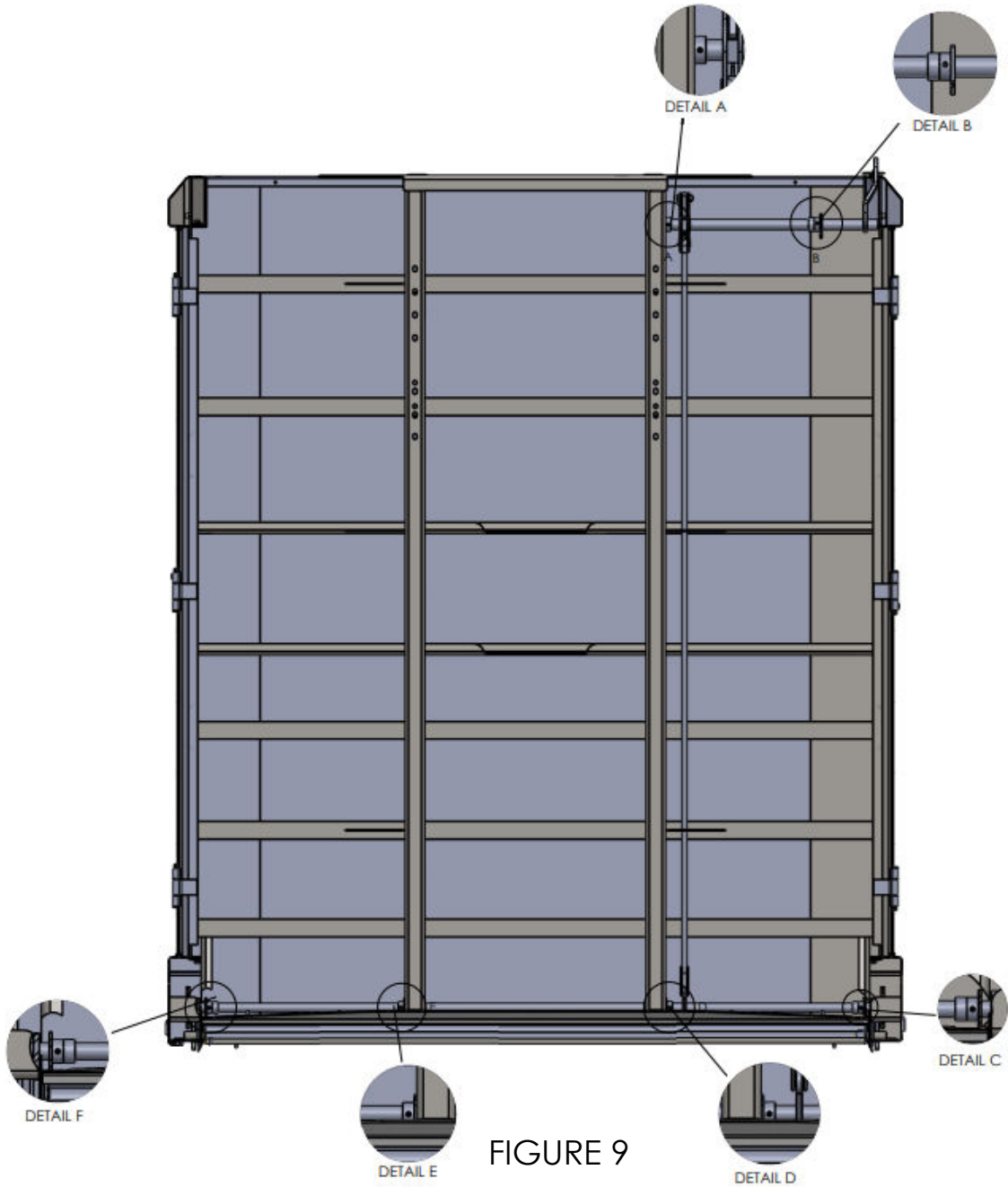

FIGURE 9

Hoist Application Reference Guide

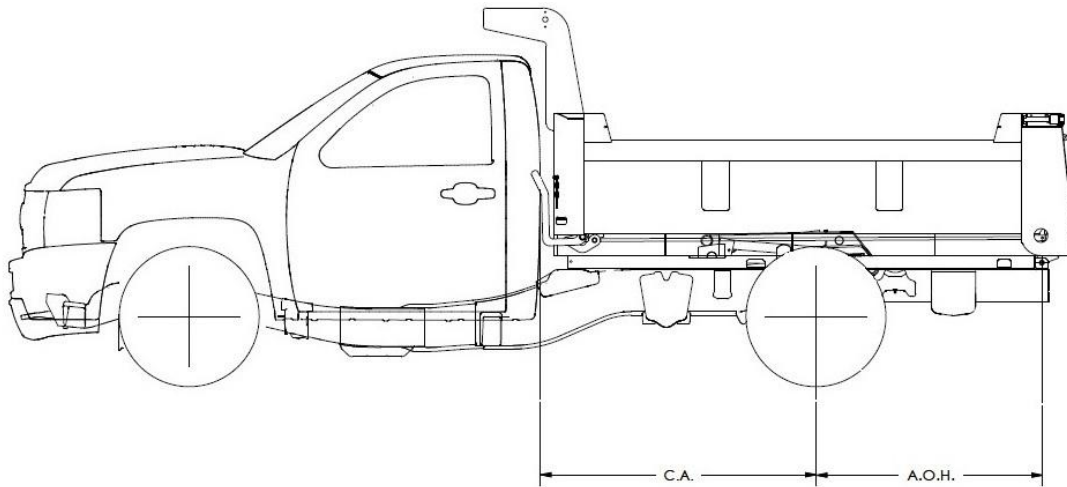

FIGURE 10

HOIST APPLICATION ELIMINATOR

SR-4016B APPLICATION CHART		
BODY LENGTH (B)	CAB/AXLE (CA) <i>in.</i>	CAPACITY 50° DUMP (STANDARD) <i>tons</i>
8'	60	12.1
9'	60	14.1
10'	84	9.4
11'	84	10.5
12'	108	7.7

SR-4020 APPLICATION CHART		
BODY LENGTH (B)	CAB/AXLE (CA) <i>in.</i>	CAPACITY 50° DUMP (STANDARD) <i>tons</i>
9'	60	12.8
10'	84	11.5
11'	84	10.3
12'	108	9.4

AXLE OVERHANG	
A.O.H. <i>in.</i>	APPLICATION
34"	STANDARD
47.6"	FORD
49"	2019 & NEWER CHEVY 4500-6500
51"/52"	GM/DODGE

Installation

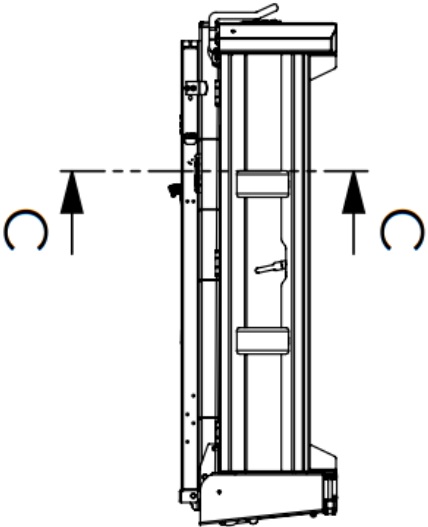

DETAIL A
SCALE 1 : 13

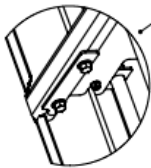

DETAIL B
SCALE 1 : 15

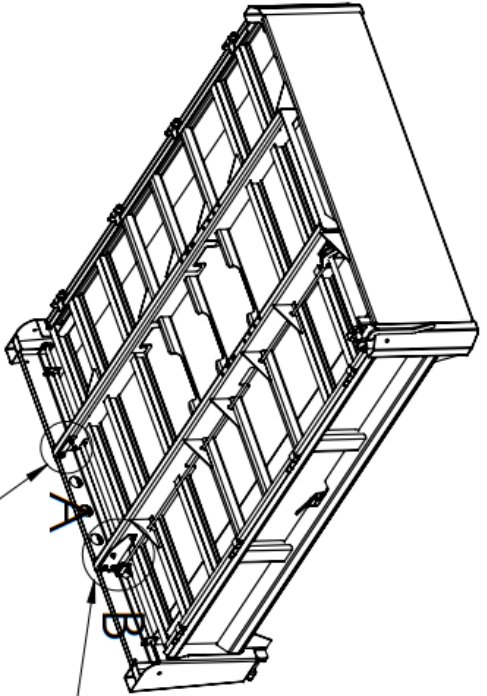
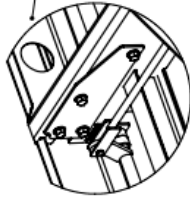

ITEM NO.	DESCRIPTION	QTY.
1	ALUMINUM LP DUMP BODY	1
2	QUICK INSTALL HOIST	1
3	LIFT SHAFT SA, BOLT-ON	2
4	BODY MOUNT PLATE, INNER REAR	2
5	BODY MOUNT PLATE, OUTER REAR	2
6	LOCK COLLAR	2
7	SET SCREW	2
8	FLANGE BOLT, 1/2-13 X 1-1/2 GR5	20
9	NUT, 1/2-13 FLANGE, GR5 STL PLT	20

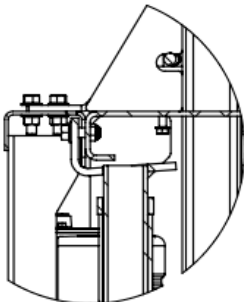

DETAIL D
SCALE 1 : 9

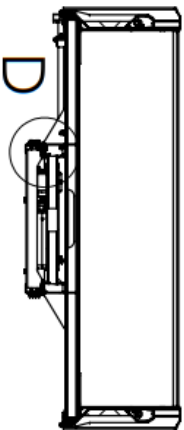

SECTION C-C
SCALE 1 : 40

Assembly Diagram

