



TRUCK BODIES & EQUIPMENT INTERNATIONAL, Inc.



Website: www.rugbymfg.com

E-mail: sales@rugbymfg.com

Phone: 1-800-869-9162

036257

MODEL LR-416B, LR-165A, & LR-25B HOIST INSTALLATION AND OPERATION MANUAL

To Be Filled In By Installer	
Hoist Serial #:	_____
Pump Installation and Operation Manual #:	_____
In Service Date:	_____
Dealer:	_____
Address:	_____
City, State ZIP:	_____
Dealer Phone Number:	_____

Use this manual *ONLY* if installing or operating a model LR-416B, LR-165A, or LR-25B hoist. This manual should be kept in the glove compartment of the truck for reference when needed.

Original Revision: December 19, 2006

Current Revision: E March 17, 2008

"HYDRAULIC SYSTEM"

The hydraulic system supplied with a given hoist manufactured by TBEI-Rugby is made up of components (pump, valves, reservoir, hoses, cylinder, etc.) that are designated to be compatible with each other.

WARNING: If you substitute hydraulic components, it is your responsibility to **BE SURE** they are compatible with the other components supplied by TBEI-Rugby. Incompatible hydraulic components may cause failure of the hoist that, in turn, could damage the vehicle, damage other property, and cause human injury or death.

All TBEI-Rugby's liability and warranty for a given hoist will be voided, if it is determined by TBEI-Rugby, that substituted hydraulic components were incompatible with those supplied by TBEI-Rugby.

Several hoist parameters are given in the following table, these parameters are given as a general guide. To ensure component compatibility, consult TBEI-Rugby.

HOIST MODEL	LR-416B	LR-165A	LR-25B
"MAXIMUM" HYDRAULIC FLOW RATE (GPM)	4 GPM	6 GPM	6 GPM
"MAXIMUM" PRESSURE FOR RAISING PORTION OF DUMP CYCLE (PSI)	3200 PSI	3200 PSI	3200 PSI
"MAXIMUM" PRESSURE FOR LOWERING PORTION OF DUMP CYCLE (PSI)	1500 PSI	1500 PSI	1500 PSI

WARNING: Adjusting the hydraulic pressure to more than the recommended setting may cause the hoist to fail during the dumping of a load. This could cause damage, serious injury, or death. **Never** adjust the pressure on your own. Consult the manufacturer if the hydraulic pressure is in question. Have only a qualified person set the hydraulic pressure. **Never** adjust the pressure to more than the recommended amount.

NOTE: A manual for the hydraulic system is supplied separate from this manual. Refer to the hydraulic system manual for details on the installation and operation of the hydraulic system.

"WARNINGS"

- WARNING:** Installing or operating this hoist without first understanding the proper installation and operation procedures can lead to serious injury or death. Always read and understand fully all installation and operation manuals before installing or operating this equipment.
- WARNING:** Welding, oxy-fuel cutting, or grinding sparks can cause fuel to ignite that in turn can lead to injury or death. **Always** take adequate steps to avoid ignition of fuel from fuel tanks when welding, grinding, or oxy-fuel cutting during equipment installation.
- WARNING:** Heat from the truck's exhaust system can cause hydraulic component failure and may lead to a fire that could cause injury or death. **Always** install equipment in locations where heat from the exhaust system will not damage any hydraulic component.
- WARNING:** Being under a raised body can result in serious injury or death should the body unexpectedly descend. **Never** position yourself or allow others to position themselves under a **loaded** body. **Always** prop the **unloaded** body up using the body prop or body props supplied. **Remember** body props are to be used only on an **unloaded** body. When two props are provided, both props must be used.
- WARNING:** Malfunctioning equipment can cause property damage, injury or death. **Always** have faulty equipment repaired before continuing its use. Consult the manufacturer if required.
- WARNING:** Overloading of a body can cause vehicle or body component damage or an accident which may cause injury or death. **Never** exceed the gross vehicle weight (GVW) or the gross axle weight (GAW) rating of your vehicle.
- WARNING:** The inadvertent shorting of the vehicle's electrical supply can cause a fire or equipment damage that could lead to injury or death. **Always** disconnect the vehicle battery prior to installing, servicing, or repairing the power unit.
- WARNING:** Damage to brake lines during equipment installation, or installing bolts or equipment in such a way that the line will rub and become damaged can lead to brake failure which can cause an accident and can lead to severe injury or death. **Always** take adequate steps to prevent brake line damage during installation and isolate brake lines from installed equipment.
- WARNING:** Connecting the hoist to a hydraulic system with more pressure (psi) or flow (gpm) than is recommended by the hoist manufacturer can cause the hoist to fail during the dumping of a load. This could lead to damage, serious injury, or death. **Be sure** you have the correct pressure and flow.

TABLE A
LR-416B APPLICATION CHART

BODY LENGTH	CA	OVERHANG	CAPACITY 40° DUMP ANGLE	CAPACITY 45° DUMP ANGLE	CAPACITY 50° DUMP ANGLE
8'	NA	12"			7.2 TONS
9'	60"	18"		7.9 TONS	7.2 TONS
9'	NA	12"	7.6 TONS	6.8 TONS	6.1 TONS
9'	72"	6"	6.6 TONS	5.9 TONS	5.4 TONS
10'	60"	30"		9.5 TONS	8.6 TONS
10'	72"	18"	7.6 TONS	6.8 TONS	6.1 TONS
10'	NA	12"	6.6 TONS	5.9 TONS	5.4 TONS
12'	72"	42"	10.7 TONS	9.5 TONS	8.6 TONS
12'	84"	30"	7.6 TONS	6.8 TONS	6.1 TONS

LR-416B

DUMP CLASS: 10

CONVERSION CLASS: B

6.00" Mounting Height

STANDARD MOUNTING	
DUMP ANGLE	M
40°	89.75"
45°	80.25"
50°	72.75"

FIGURE 1A

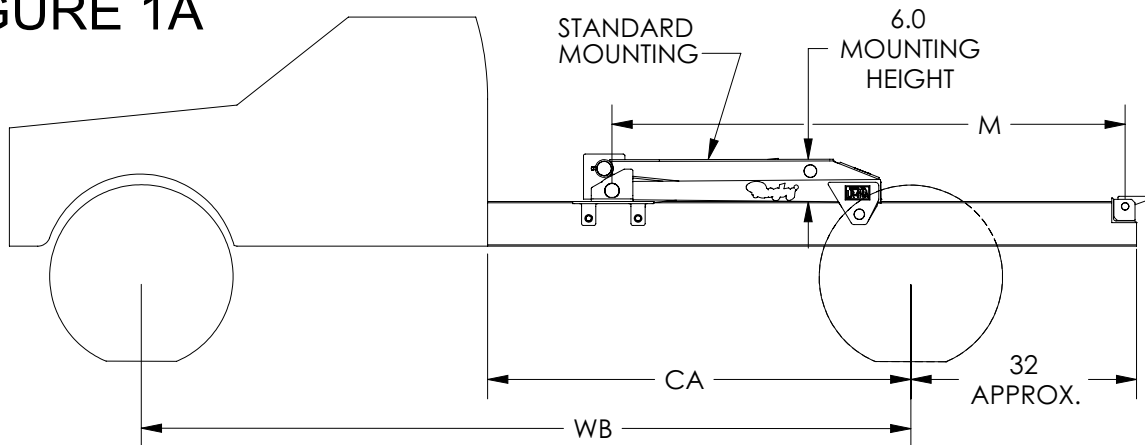

Capacities are based on the following:

1. Water level non-diminishing loads.
2. The hydraulic relief pressure set at the maximum 3,200 psi (see page 2 of this manual).

IMPORTANT: Because of variations in applications, the data contained in this sheet is provided only as a general guide.

TABLE A
LR-165A APPLICATION CHART

BODY LENGTH	CA	OVERHANG	CAPACITY 40° DUMP ANGLE	CAPACITY 45° DUMP ANGLE	CAPACITY 50° DUMP ANGLE
8'	NA	12"		11.8 TONS	10.7 TONS
9'	60"	18"		11.8 TONS	10.7 TONS
9'	NA	12"	11.4 TONS	10.1 TONS	9.2 TONS
9'	72"	6"	10.0 TONS	8.9 TONS	8.0 TONS
10'	60"	30"		14.2 TONS	12.9 TONS
10'	72"	18"	11.4 TONS	10.1 TONS	9.2 TONS
10'	NA	12"	10.0 TONS	8.9 TONS	8.0 TONS
12'	72"	42"	16.0 TONS	14.2 TONS	12.9 TONS
12'	84"	30"	11.4 TONS	10.1 TONS	9.2 TONS
13'	84"	42"	13.3 TONS	11.8 TONS	10.7 TONS
13'	102"	24"	8.8 TONS	7.9 TONS	7.1 TONS

LR-165A

DUMP CLASS: 20

CONVERSION CLASS: C

6.00" Mounting Height

REVERSE		STANDARD
M	DUMP ANGLE	M
91.50"	40°	90.50"
81.75"	45°	80.75"
74.25"	50°	73.25"

FIGURE 1B

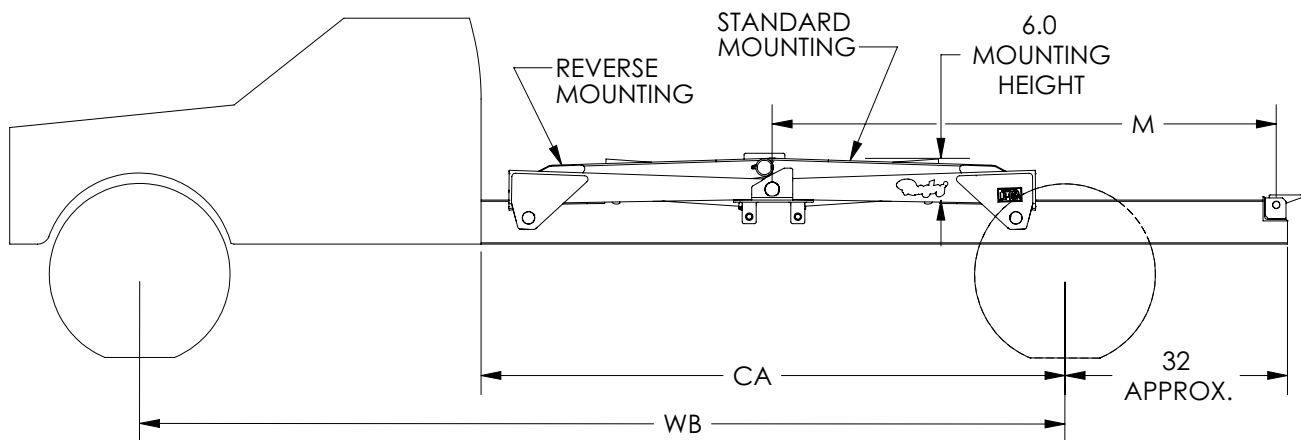

Capacities are based on the following:

1. Water level non-diminishing loads.
2. The hydraulic relief pressure set at the maximum 3,200 psi (see page 2 of this manual).

IMPORTANT: Because of variations in applications, the data contained in this sheet is provided only as a general guide.

TABLE A
LR-25B APPLICATION CHART

BODY LENGTH	CA	OVERHANG	CAPACITY 40° DUMP ANGLE	CAPACITY 45° DUMP ANGLE	CAPACITY 50° DUMP ANGLE
10'	NA	12"		11.6 TONS	10.5 TONS
12'	84"	30"	14.8 TONS	13.2 TONS	12.0 TONS
13'	84"	42"	17.2 TONS	15.4 TONS	14.0 TONS
13'	102"	24"	11.5 TONS	10.3 TONS	9.3 TONS
14'	102"	36"	12.9 TONS	11.6 TONS	10.5 TONS
14'	108"	30"	11.5 TONS	10.3 TONS	9.3 TONS
15'	102"	48"	14.8 TONS	13.2 TONS	12.0 TONS
15'	108"	42"	12.9 TONS	11.6 TONS	10.5 TONS

LR-25B

DUMP CLASS: 40

CONVERSION CLASS: D

7.50" Mounting Height

REVERSE		STANDARD
M	DUMP ANGLE	M
106.50"	40°	108.75"
95.25"	45°	97.25"
86.00"	50°	88.25"

FIGURE 1C

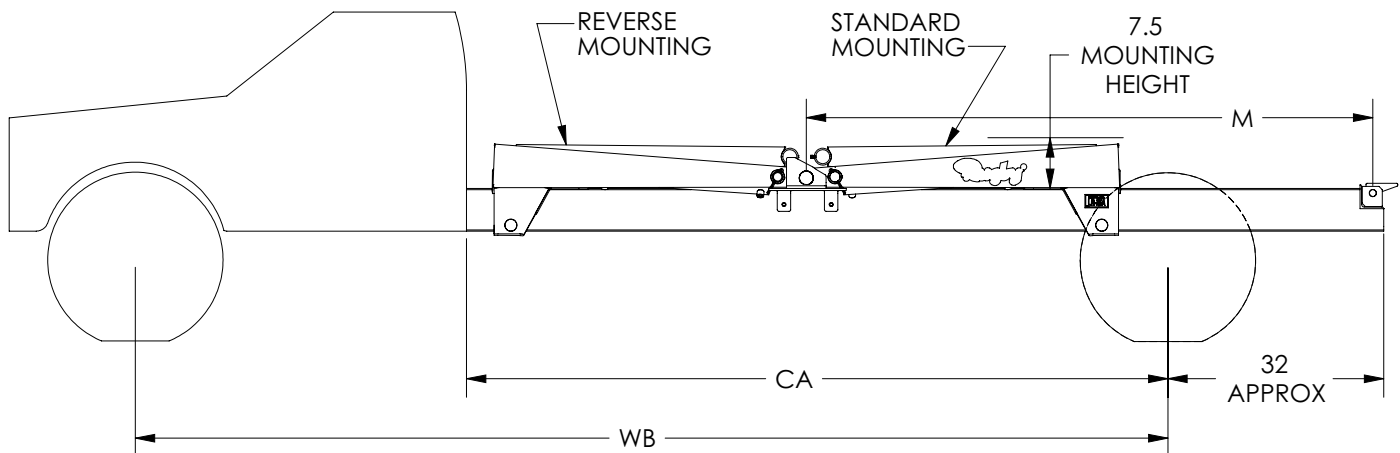

Capacities are based on the following:

1. Water level non-diminishing loads.
2. The hydraulic relief pressure set at the maximum 3,200 psi (see page 2 of this manual).

IMPORTANT: Because of variations in applications, the data contained in this sheet is provided only as a general guide.

"INSTALLATION INSTRUCTIONS"

1. Mark the location for the rear hinge. This location should be immediately behind a truck cross member, approximately 32" behind the center of the rear axle on single axle trucks. Refer to Figure 1 for the specific hoist model you are installing.
2. Referring to Fig #2, cut a notch as shown.

NOTE

TO DETERMINE NOTCH HEIGHT. SUBTRACT THE DISTANCE FROM THE BOTTOM OF THE LONG SILL TO THE TOP OF CHASSIS FRAME FROM 3 3/4 INCHES.

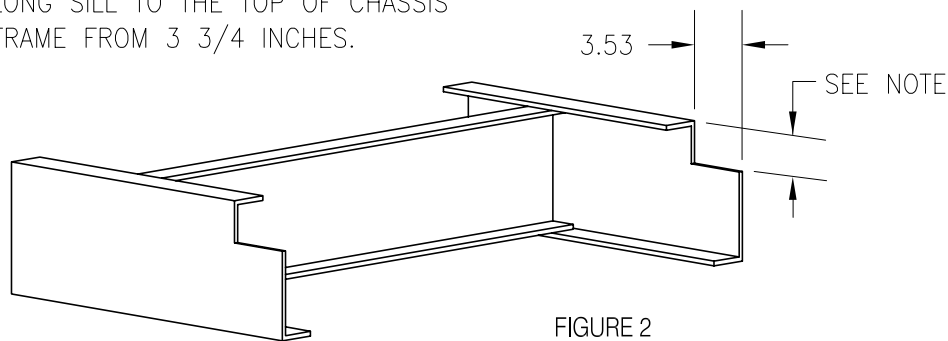

3. Position the rear hinge angle in the notch cut in Step 2. The rear hinge angle is 37 3/16" wide and should be centered side to side in the notch as illustrated in Figure 3. Weld the rear hinge angle to each of the truck chassis frame rails.

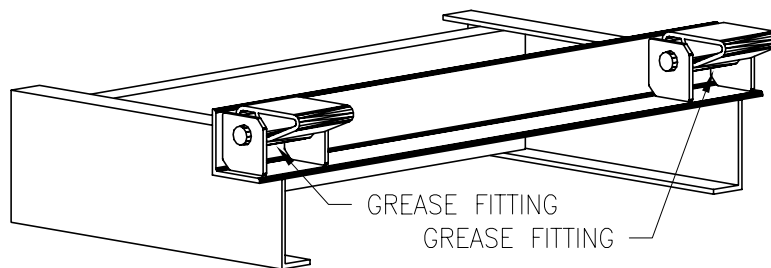

NOTE: This hinge assembly is designed for a truck longsill spacing of 34" and is not recommended for any other width.

NOTE: The distance between the rear hinge shaft center and the saddle center is referred to as the "M" dimension. In Figure 1, the "M" dimension for several dump angles are tabulated.

NOTE: Moving the hoist rearward or forward along the truck frame will affect the hoist's performance. A forward movement will reduce the dump angle and will increase capacity while a rearward movement will increase the dump angle and reduce capacity.

NOTE: If an obstruction can not be cleared by moving the hoist forward or rearward, the hoist may be reverse mounted as shown in Figure 1.

4. Slide each saddle bracket into the lower tube as shown in Figure 5.
5. Locate the hoist on the truck frame, making sure to center the hoist right and left, and to square the hoist with the truck frame. This hoist is designed to rest on the truck frame as shown in Fig. #1. A small portion of the hoist extends below the truck frame level. The hoist may have to be moved forward or rearward to avoid obstructions below the frame level.
6. Slide a lock collar onto each lifting shaft. Slide a lifting shaft with collar into each end of the hoist lifting tube. See Figure 4.

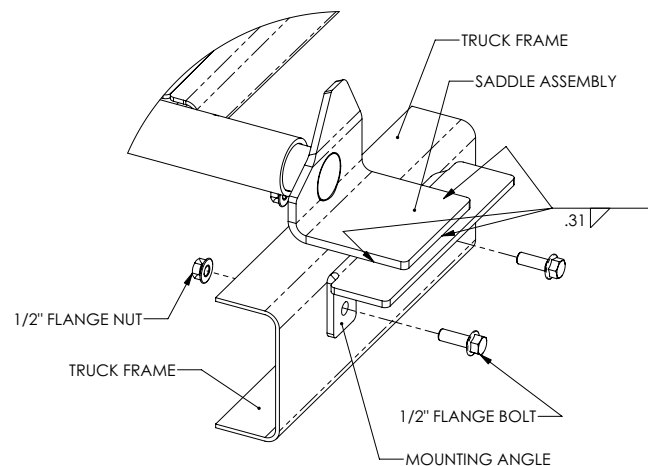
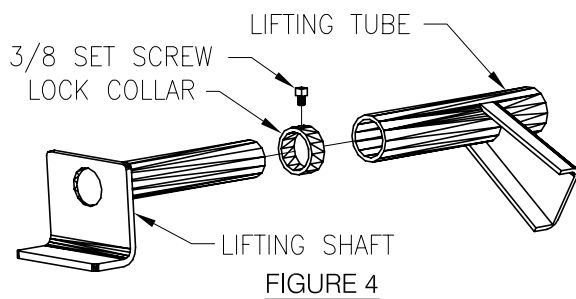

FIGURE 5

7. When the hoist is positioned, place a mounting angle under each side of the hoist saddle. Secure each mounting angle to the truck frame by drilling two 17/32" dia. holes and installing two 1/2" flange screws and two 1/2" flange nuts. Torque all 1/2" fasteners to 90 ft-lb. See Figure 5
8. Weld each saddle bracket to the corresponding mounting angle. See Figure 5.

NOTE: **Do not** weld the hoist or mounting angle to the truck frame.

NOTE: The hoist saddle must set directly on the truck frame. If rivet interference is encountered, counter sink the rivet head into the hoist saddle.

9. Position and secure the liner (sleeper) to the truck frame. The LR-416B or LR-165A hoist requires at least 5 3/4" of clearance above the truck frame. As an example, if 4" long beams are on the truck body, a liner of at least 1 3/4" will be required to gain enough room, 5 3/4", for mounting the LR-416B or LR-165A. Similarly, a LR-25B requires 7 1/2" of clearance.

10. Position the body with the long beams (just long beams if they are separate from the body) onto the truck frame.

NOTE: A clearance of at least 2" is required between the truck cab and the closest point on the truck body.

11. Position the rear hinge brackets against the long beams. Once in position, weld the rear hinge brackets to the body long beams as shown in Figure 6.

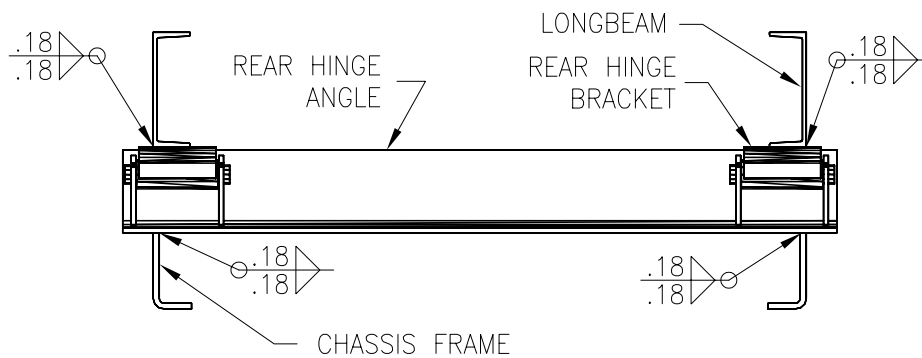

FIGURE 6

12. Slide each of the lifting shafts all the way against the inside of the long beam. Weld the lifting shaft angles to secure the shaft to the long beam as shown in Figure 7. With the shaft secured, slide the lock collars against the hoist lifting tube and lock them there by tightening the set screw (see Figure 4 & 7). Torque the setscrew to 24 ft-lb.

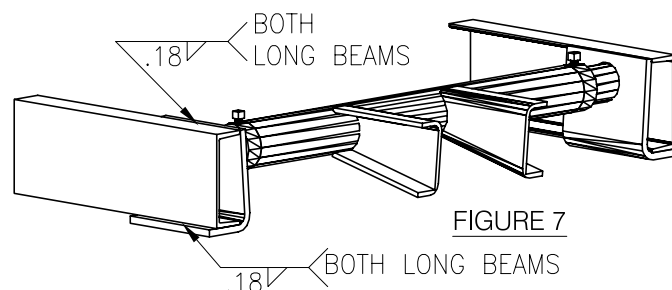

FIGURE 7

13. Install all grease fittings. For grease fitting locations in the hoist, refer to Figure 12. Torque each grease fitting to 70 in-lb. Grease all grease fittings on both the hoist and the rear hinge.
14. Install the body prop. Refer to the "**BODY PROP**" section of this manual.
15. Install the hydraulic system. Cycle the hoist several times to rid the hydraulic circuit of air.

IMPORTANT: Several different types of hydraulic components are used to power this hoist. All hydraulic systems supplied by TBEI-Rugby have an installation and operation manual included with them. For installation and operation information, refer to the Installation and Operation Manual for your particular hydraulic components. **BE SURE** to read and understand this manual and the installation and operating instructions included with the hydraulic system before you attempt to operate this hoist.

WARNING: Installing or operating this hoist without first understanding the proper installation and operation procedures can lead to serious injury or death. Always read and understand fully all installation and operation manuals before installing or operating this equipment.

NOTE: Before operating the hoist, read the "**OPERATION**" section of this manual

WARNING: If it is necessary to work on the hoist or body while in the raised position, **ALWAYS** block the unloaded body up securely with the body prop or body props.

16. Place a complete operation manual in the glove compartment of the truck. This manual **MUST BE** available for reference by the operator when needed.

WARNING: If the hydraulic system used to power this hoist was supplied by TBEI-Rugby, an operation manual will be included with the hydraulic components. The operation manual for this hydraulic system **MUST BE** supplied to the operator.

WARNING: If the hydraulic system used to power this hoist was supplied by someone other than TBEI-Rugby, an operation manual for this hydraulic system **MUST BE** obtained and supplied to the operator.

17. Install all decals. Refer to "**DECAL LOCATION**" section of this manual.

"BODY PROP"

NOTE: In order to comply with paragraph 10 of Federal Regulation #1926.601, all TBEI-Rugby hoists will be sold with one body prop. It is the responsibility of the installer to determine whether one body prop is sufficient. The following information will help in making that determination.

The body prop is designed for use only when the body is empty. The purpose of the body prop is to hold an empty body in the raised position when performing maintenance or inspection on the hoist, body, or any component that requires working under an **empty** body.

Some applications may require 2 or more body props to support the **empty** body. To determine how many body props your application requires, refer to the following information.

WARNING: Being under a raised body can result in serious injury or death should the body inadvertently descend. **Never** position yourself or allow others to position themselves under a **loaded** body. **Always** prop the **unloaded** body up using the body prop/s supplied. **Remember**, body props are to be used only on an **unloaded** body. When two props are provided, both props must be used.

WARNING: Do not use body prop to support a loaded body!

WARNING: Do not perform maintenance under a raised body without first blocking the empty body up with the body prop/s.

WARNING: Do not use a body prop that is bent or otherwise damaged. A damaged body prop will have a reduced holding capacity, and may break when used to hold up the body. This could cause serious injury or death. Replace a damaged body prop before using it.

WARNING: Be sure to install the body prop according to the "**INSTALLATION OF BODY PROP**" section of this manual.

The following is a step by step procedure to determine how many body props are required for this application.

1. The TBEI-Rugby Part Number 03 0700 body prop is to be used with this hoist. Determine if this is the body prop you have by referring to Figure 8.
2. Determine the "P" value referring to Figure 9. The "P" value is the horizontal distance between the rear hinge and the prop.

3. Determine the "X" value referring to Figure 9. The "X" value is the horizontal distance between the body center of gravity and the rear hinge when the body is empty and down. Be sure to include any items attached to the body such as toolboxes or other structures when determining the center of gravity.

FIGURE 8

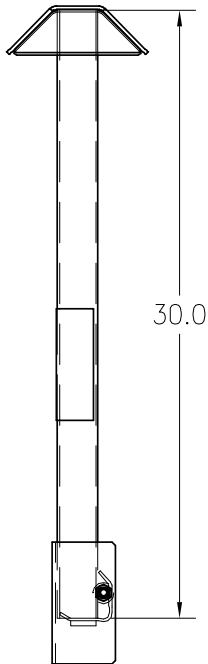

03 0700 Body Prop.
30" Tube.

FIGURE 9

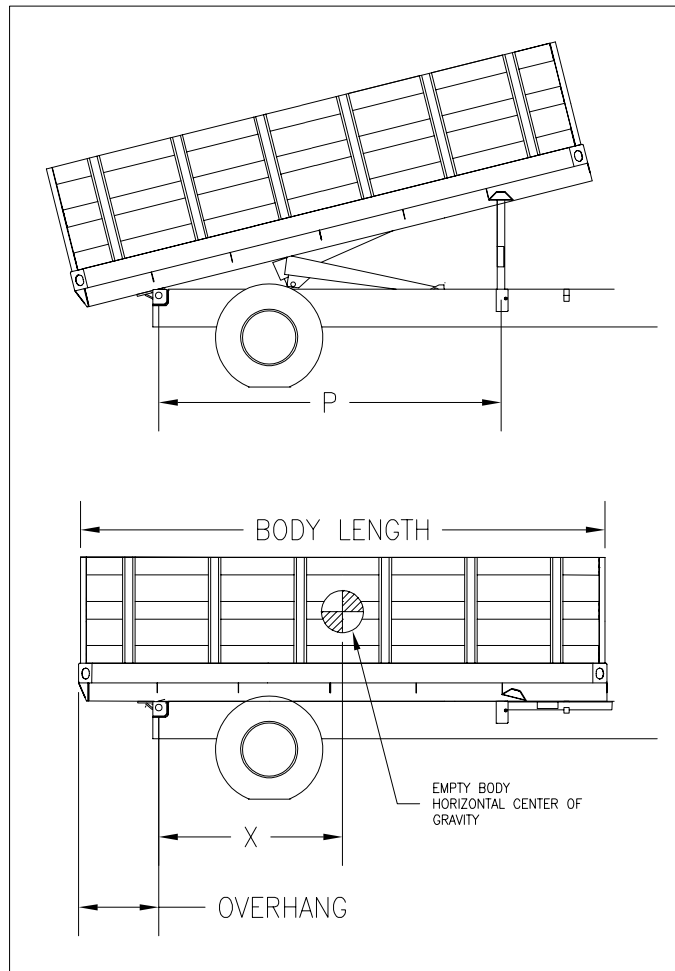

4. On the left side of Chart 1, pick the "P" value for your application. On the top of the same chart, pick the "X" value for your application. Below the "X" value and to the right of the "P" value is listed an amount of weight. This represents the maximum weight that the body can weigh and be supported by only one body prop. If the body weighs more than the amount listed, 2 body props will be required. Contact TBEI-Rugby to order another body prop.

NOTE: If the body weighs more than 2 times the amount listed, another type of body prop with more weight capacity will be required, as 2 body props will not support this empty body.

CHART 1

03 0700 BODY PROP CAPACITY

Maximum Body Weight per Body Prop											
		Distance Rear Hinge - Center of Gravity (X)									
		0-36	37-48	49-60	61-72	73-84	85-96	97-108	109-120	121-132	133-144
Distance Rear Hinge - Body Prop (P)	42-47	6,100	4,500	3,500	2,800	2,300	2,000	1,700	1,500	1,300	1,100
	48-53	6,600	4,800	3,800	3,000	2,500	2,100	1,800	1,600	1,400	1,200
	54-59	7,200	5,200	4,100	3,300	2,800	2,300	2,000	1,800	1,600	1,400
	60-65	7,700	5,700	4,400	3,600	3,000	2,600	2,200	1,900	1,700	1,500
	66-71	8,300	6,100	4,800	3,900	3,300	2,800	2,400	2,100	1,900	1,700
	72-77	8,900	6,600	5,100	4,200	3,500	3,000	2,600	2,300	2,000	1,800
	78-83	9,500	7,000	5,500	4,500	3,800	3,200	2,800	2,500	2,200	2,000
	84-89	10,200	7,500	5,900	4,800	4,000	3,500	3,000	2,700	2,400	2,100
	90-95	10,800	7,900	6,200	5,100	4,300	3,700	3,200	2,800	2,500	2,300
	96-101	11,400	8,400	6,600	5,400	4,600	3,900	3,400	3,000	2,700	2,400
	102-107	12,100	8,900	7,000	5,800	4,900	4,200	3,700	3,200	2,900	2,600
	108-115	12,700	9,400	7,400	6,100	5,100	4,400	3,900	3,400	3,100	2,800
	114-119	13,400	9,900	7,800	6,400	5,400	4,700	4,100	3,600	3,200	2,900
	120-125	14,000	10,400	8,200	6,700	5,700	4,900	4,300	3,800	3,400	3,100
	126-131	14,700	10,900	8,600	7,100	6,000	5,200	4,500	4,000	3,600	3,300
	132-137	15,300	11,400	9,000	7,400	6,300	5,400	4,700	4,200	3,800	3,400
138-143	16,000	11,800	9,400	7,700	6,500	5,600	5,000	4,400	4,000	3,600	
144+	16,600	12,300	9,800	8,000	6,800	5,900	5,200	4,600	4,100	3,700	

EXAMPLE: Using a 12' body that has an empty weight of 6,000 pounds. Body is installed with a 18" overhang. The prop is located 84" forward of the rear hinge. Assume the center of gravity is 72" from the rear of the body. Subtract the overhang to get X=54". Using P=84-89, X=49-60, the maximum body weight is 5,900 pounds. This application needs 2 body props.

Remember, this is an example only, and in no way means that this hoist **is** or **is not** acceptable to use in this application.

"INSTALLATION OF BODY PROP"

NOTE: The following steps are to be used as a guideline when installing the body prop. Since trucks will vary according to their design it is not possible to be specific about every aspect of the body prop installation.

1. Once the TBEI-Rugby hoist has been installed, raise the hoist up and temporarily block the body up. Position the prop assembly against the truck frame as illustrated in Figure 9.
2. Fasten the body prop assembly base to the truck frame.
3. Position and fasten the prop hanger to the truck frame. Hanger must be installed so that when the body is down the body prop leg will not bounce out of the hanger.
4. Position and weld the prop cup on the body as illustrated in Figure 10.

NOTE: To raise and lower body prop, see the "**OPERATION OF BODY PROP**" section of this manual.

FIGURE 10

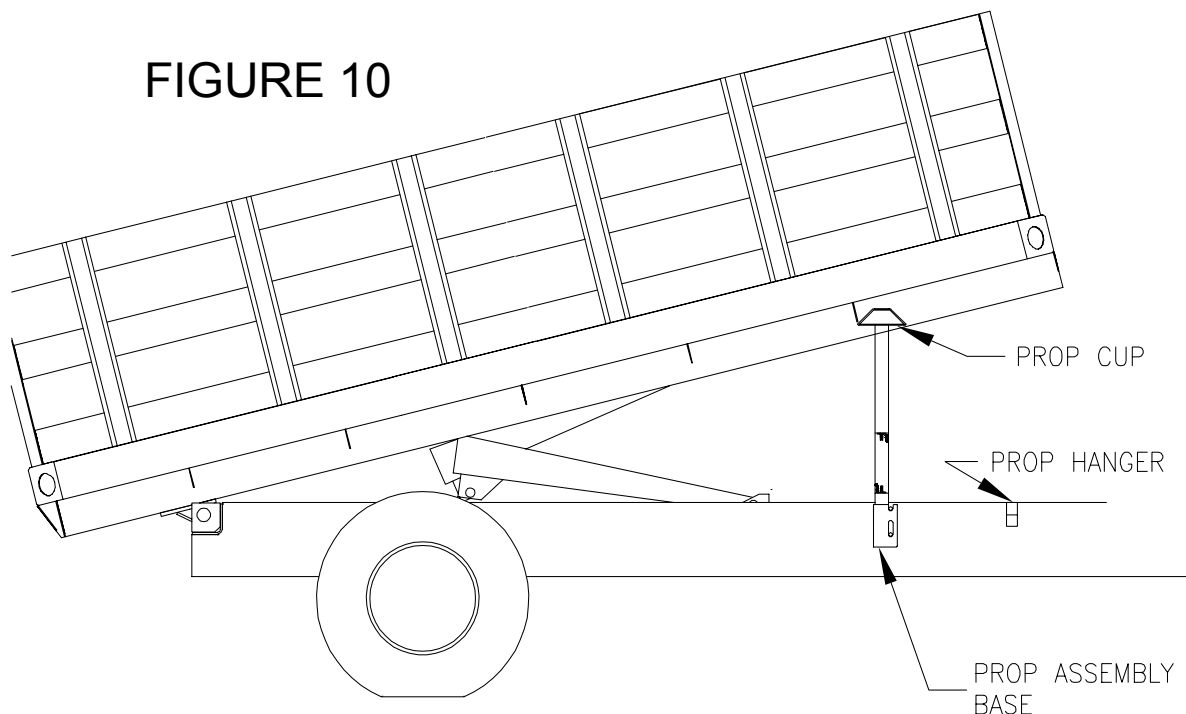

MOUNTING OF BODY PROP (FOR REFERENCE PURPOSES ONLY)

"DECAL LOCATION"

Two "DANGER" decals, as shown on this page are supplied with each hoist. These decals should be positioned as shown in Figure 11. The part number of the "DANGER" decal is 03 6039.

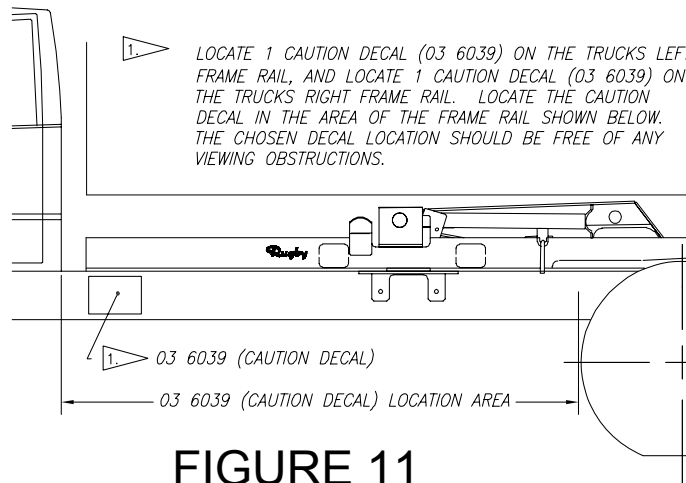

FIGURE 11

WARNING: Missing or damaged decals can cause incorrect or unsafe operation of the hoist, which can cause accidents, which may cause serious injury or death. If any decals are missing or damaged, they must be replaced.

To obtain replacement decals, contact your TBEI-Rugby dealer or call 1-701-776-5722 or 1-800-869-9162.



DANGER



1. STAY OUT FROM UNDER BODY WHEN HOIST IS OPERATING.
2. DURING DUMPING OPERATIONS, NO ONE MUST BE ALLOWED TO STAND IN OR MOVE THROUGH THE AREA WHERE THE BODY AND HOIST OPERATE OR INTO AN AREA WHERE AN UPSET LOAD MIGHT FALL.
3. OPERATOR MUST REMAIN AT CONTROLS IN CAB DURING DUMPING OPERATIONS.
4. NEVER LEAVE BODY RAISED OR PARTLY RAISED WHILE VEHICLE IS UNATTENDED OR PERFORMING MAINTENANCE OR SERVICE UNDER BODY, UNLESS BODY IS BRACED TO PREVENT ACCIDENTAL LOWERING.
5. IF HOIST PUMP IS PTO DRIVEN, ALWAYS DISENGAGE PTO WHEN HOIST IS NOT IN USE OR WHEN MOVING VEHICLE.
6. DO NOT ATTEMPT TO RAISE A LOADED BODY WHEN THE VEHICLE IS ON UNLEVEL GROUND.
7. NEVER JERK OR SHOCK A RAISED BODY TO LOOSEN A STUCK LOAD.



03 6039

"LUBRICATION"

IMPORTANT: All grease fittings should be greased at least twice annually. Refer to Figure 12 for grease fitting locations. Failure to grease hoist will result in hoist failure. Hoist failure due to lack of grease is not covered by the warranty.

IMPORTANT: Refer to installation and operation manual of the hydraulic system for hydraulic system lubrication instructions.

1. Grease all of the grease fittings in the hoist frame itself. Apply grease until excess grease can be seen coming out the ends of the tubes. Refer to Figure 12 for grease fitting locations. Replace any missing or broken grease fittings.
2. Grease the two grease fittings in the truck rear hinge.
3. Check oil level in the pump reservoir every time the oil is changed in the truck engine. **REMEMBER** keep the oil clean. An annual oil change can prevent contaminants from ruining your pump and hoist cylinder.

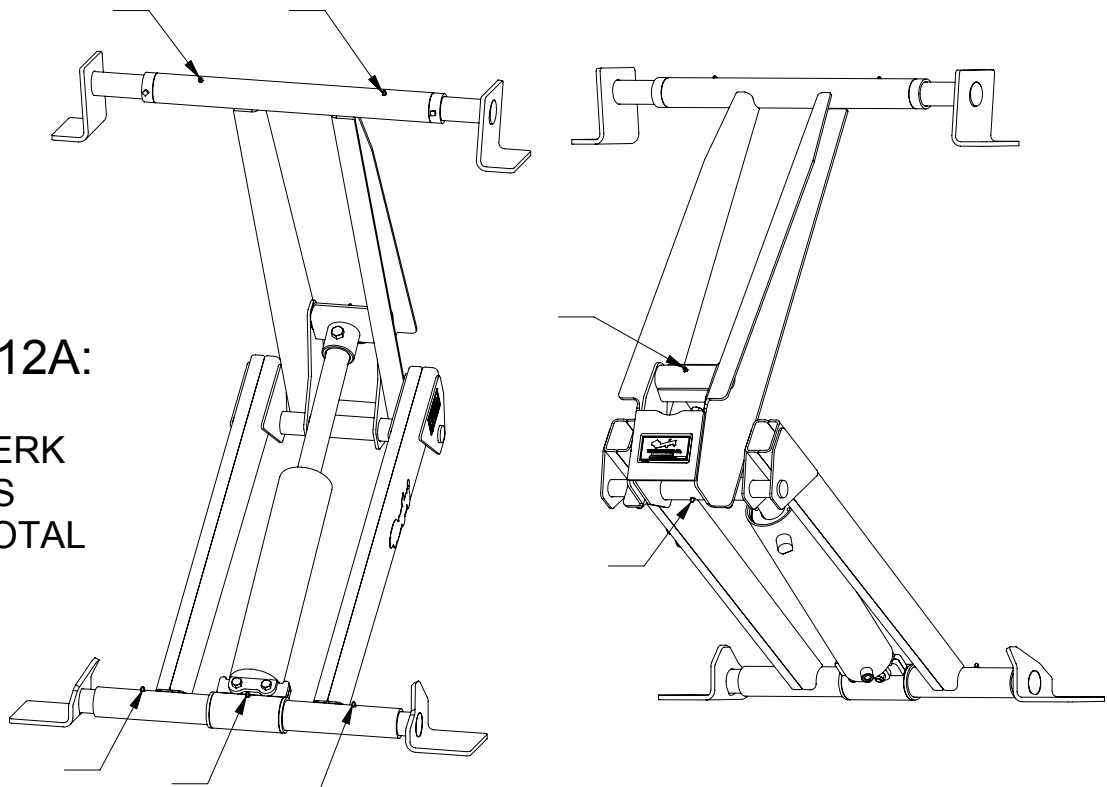

FIGURE 12A:
LR-416B
GREASE ZERK
LOCATIONS
7 ZERKS TOTAL

FIGURE 12B:
LR-165A
GREASE ZERK
LOCATIONS
8 ZERKS TOTAL

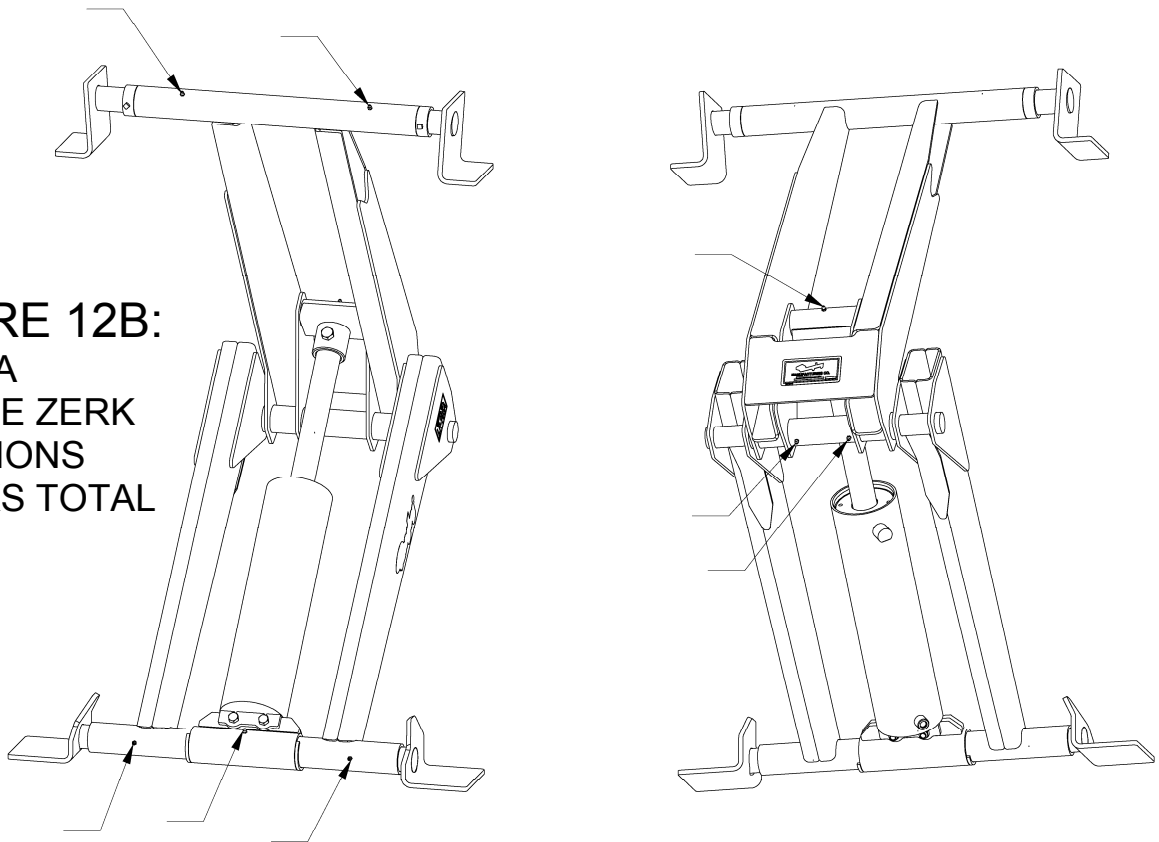
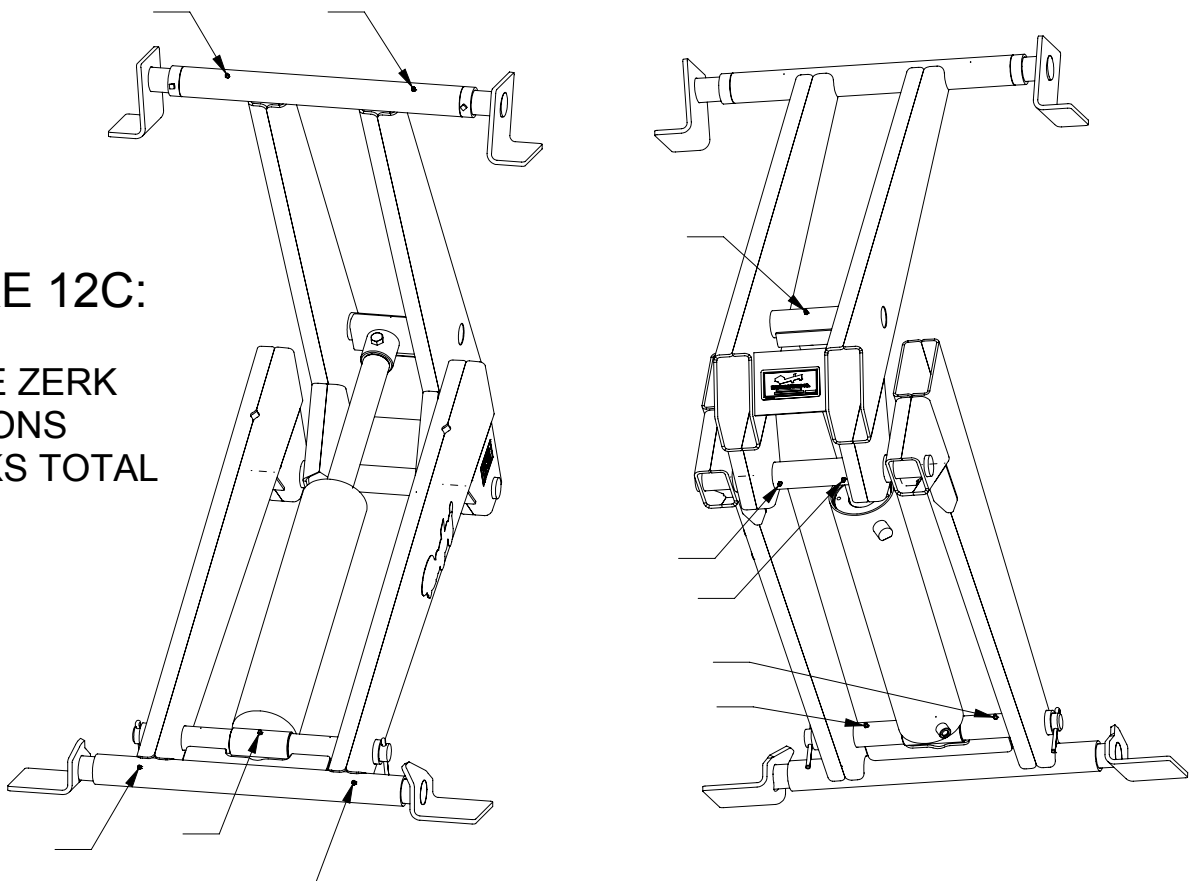

FIGURE 12C:
LR-25B
GREASE ZERK
LOCATIONS
10 ZERKS TOTAL



"OPERATION OF BODY PROP"

WARNING: Being under a raised body can result in serious injury or death should the body unexpectedly descend. **Never** position yourself or allow others to position themselves under a **loaded** body. **Always** prop the **unloaded** body up using the body prop or body props supplied. **Remember**, body props are to be used only on an **unloaded** body. When two props are provided, both props must be used.

Below is a step-by-step procedure for using the body prop.

1. Raise body to sufficient height and shut off all power.
2. Grasp prop handle at arms length and rotate prop upwards.
3. Swing prop up to vertical position and push down until prop locks in line with support bracket on the body.
4. Using inside-the-cab controls, lower body slowly until prop contacts prop cup.

CAUTION: Do not power hoist down while on prop.

5. To lower prop for normal operation, "reverse" the procedure of the above four steps.

"OPERATION OF HOIST AND PUMP"

WARNING: Operating this hoist without first understanding the proper operation procedures can lead to serious injury or death. Always read and understand fully all operation manuals before using or operating this equipment.

WARNING: An operation manual for the hydraulic system should be available. The operation manual for the supplied hydraulic system **MUST BE** read and understood before operating this trailer.

WARNING: Being under a raised body can result in serious injury or death should the body unexpectedly descend. **Never** position yourself or allow others to position themselves under a **loaded** body. **Always** prop the **unloaded** body up using the body prop or body props supplied. **Remember**, body props are to be used only on an **unloaded** body.

DANGER:

1. Stay out from under body when hoist is operating.
2. During dumping operations, no one must be allowed to stand in or move through the area where the body and hoist operate or into an area where an upset load might fall.
3. Controls must be in a safe location and operator must remain at controls during the dumping operation. Controls must be permanently located in truck cab or another location where it is not possible to be under body during dumping operation.
4. **Never** leave body raised or partly raised while the truck is unattended or while performing maintenance or service under body, unless body is braced to prevent accidental lowering.
5. If hoist pump is direct engine driven by truck, always disengage drive when hoist is not in use or when moving load.
6. **Do not** attempt to raise a loaded body when the vehicle is on un-level ground.
7. Never jerk or shock a raised body to loosen a stuck load.

WARNING: Freeing a stuck load during dumping, with the body raised, by jerking or shocking the truck, may cause damage to the truck, serious injury or death. **Never** drive forward or rearward and stop quickly with the load up or otherwise shock the load. If a load is stuck in the body, lower the body, then free the load.

WARNING: Attempting to dump a load on un-level ground may cause the truck to over turn, and can result in damage, serious injury or death. **Always** dump the load on ground that is level front to rear as well as level side to side.

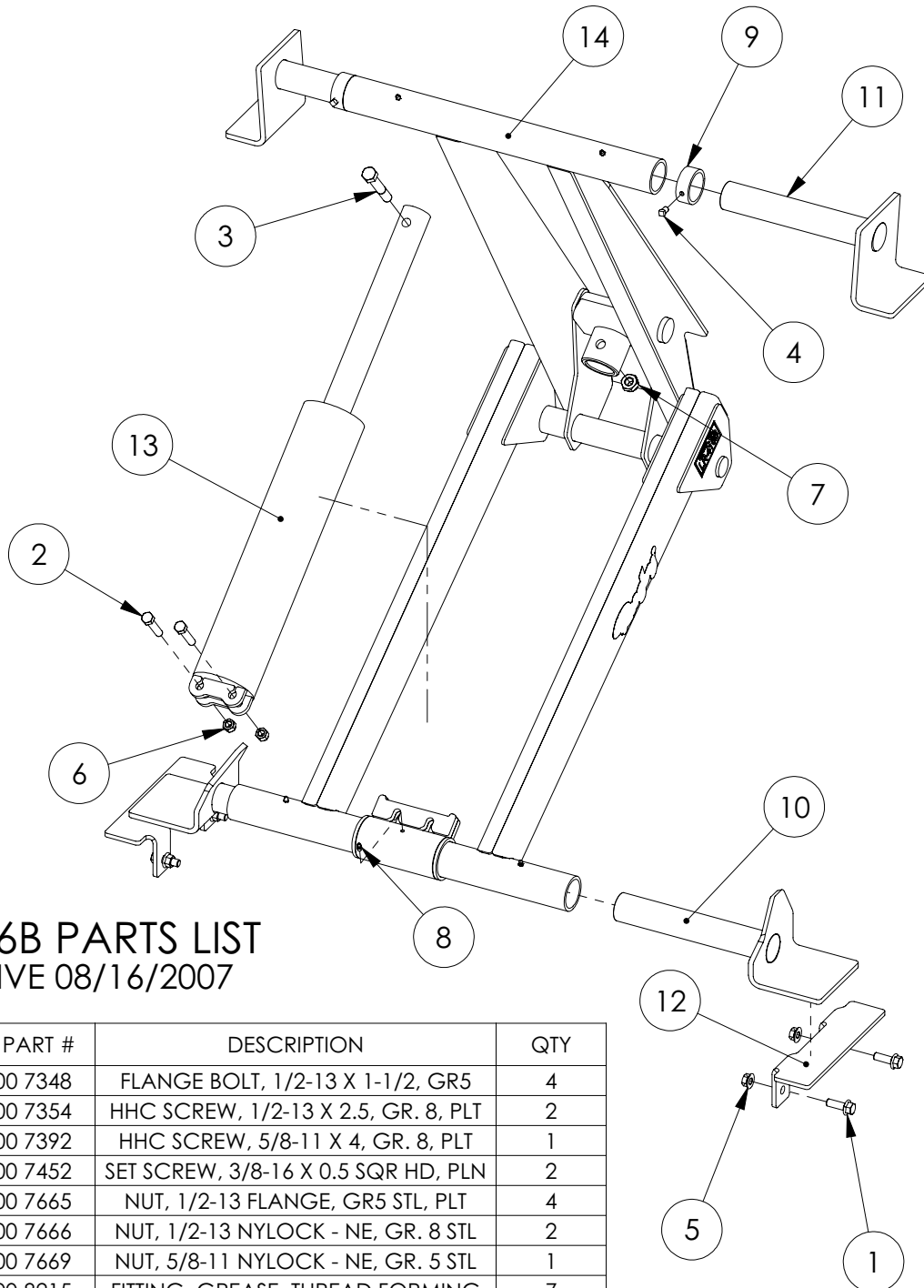

LR-416B PARTS LIST
EFFECTIVE 08/16/2007

ITEM	PART #	DESCRIPTION	QTY
1	00 7348	FLANGE BOLT, 1/2-13 X 1-1/2, GR5	4
2	00 7354	HHC SCREW, 1/2-13 X 2.5, GR. 8, PLT	2
3	00 7392	HHC SCREW, 5/8-11 X 4, GR. 8, PLT	1
4	00 7452	SET SCREW, 3/8-16 X 0.5 SQR HD, PLN	2
5	00 7665	NUT, 1/2-13 FLANGE, GR5 STL, PLT	4
6	00 7666	NUT, 1/2-13 NYLOCK - NE, GR. 8 STL	2
7	00 7669	NUT, 5/8-11 NYLOCK - NE, GR. 5 STL	1
8	00 8215	FITTING, GREASE, THREAD FORMING	7
9	03 0668	LOCK COLLAR	2
10	03 1782	SADDLE BRKT ASSY, SET, 416/165/25	1
11	03 1795	LIFT ANGLE SA, LR-416/165/25	2
12	03 2010	ANGLE BRACKET, MOUNTING	2
13	032586	CYLINDER, 4X16, TH-410	1
14	032928	FRAME WELDMENT, LR-416B	1

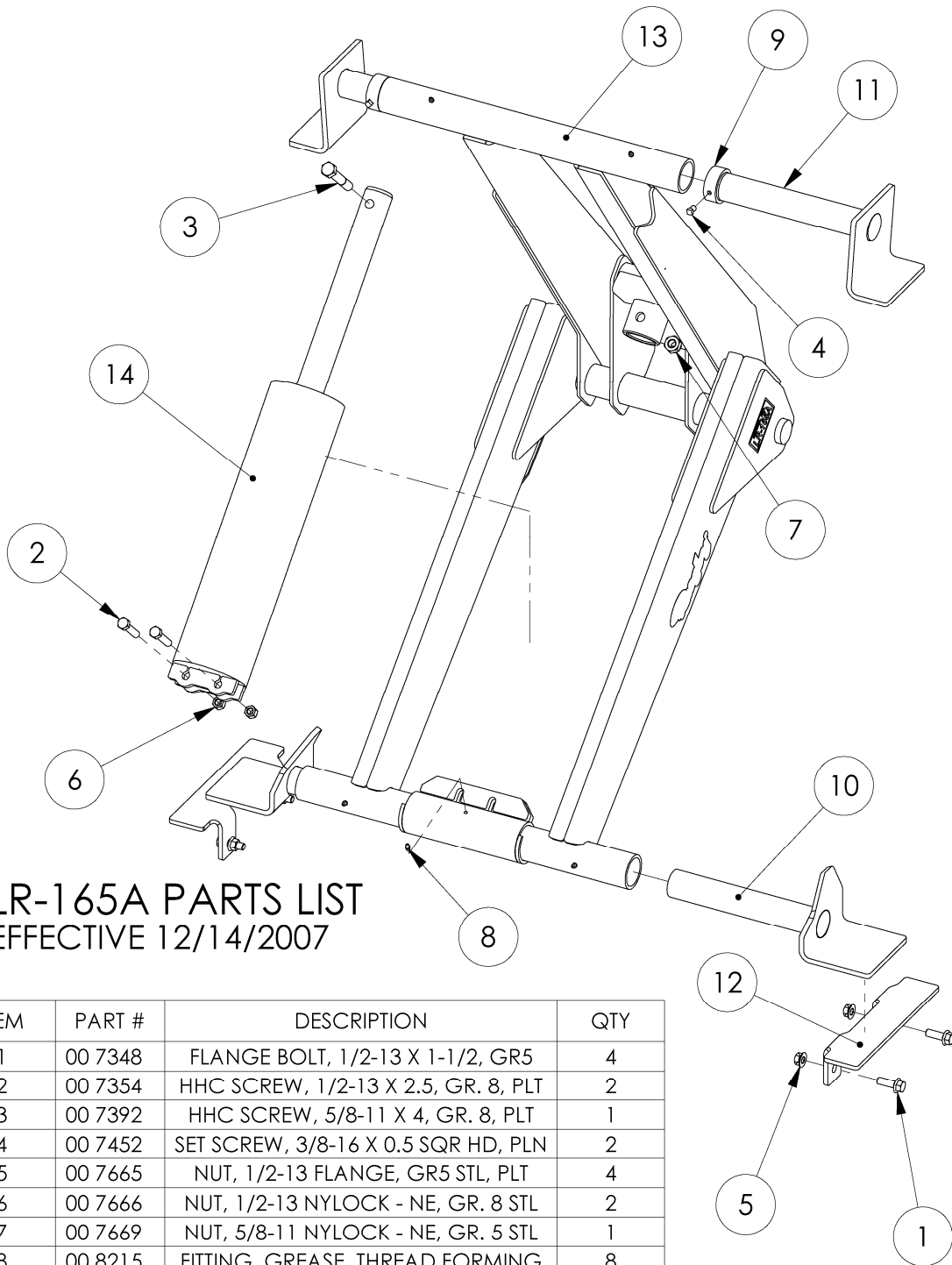

LR-165A PARTS LIST
EFFECTIVE 12/14/2007

ITEM	PART #	DESCRIPTION	QTY
1	00 7348	FLANGE BOLT, 1/2-13 X 1-1/2, GR5	4
2	00 7354	HHC SCREW, 1/2-13 X 2.5, GR. 8, PLT	2
3	00 7392	HHC SCREW, 5/8-11 X 4, GR. 8, PLT	1
4	00 7452	SET SCREW, 3/8-16 X 0.5 SQR HD, PLN	2
5	00 7665	NUT, 1/2-13 FLANGE, GR5 STL, PLT	4
6	00 7666	NUT, 1/2-13 NYLOCK - NE, GR. 8 STL	2
7	00 7669	NUT, 5/8-11 NYLOCK - NE, GR. 5 STL	1
8	00 8215	FITTING, GREASE, THREAD FORMING	8
9	03 0668	LOCK COLLAR	2
10	03 1782	SADDLE BRKT ASSY, SET, 416/165/25	1
11	03 1795	LIFT ANGLE SA, LR-416/165/25	2
12	03 2010	ANGLE BRACKET, MOUNTING	2
13	032959	FRAME WELDMENT, LR-165A	1
14	10 0528	CYLINDER, 5 X 16, HR-520	1

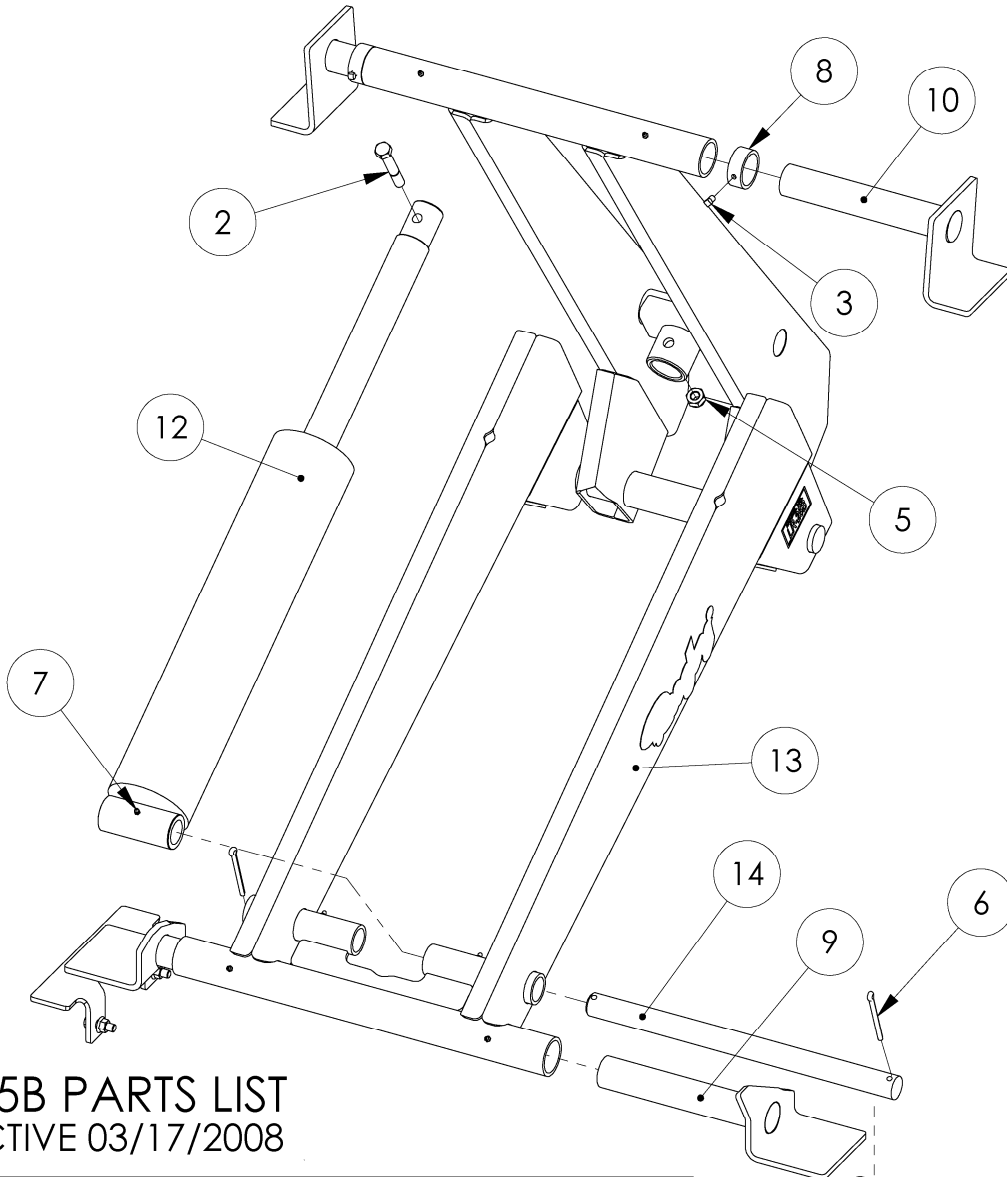

LR-25B PARTS LIST
EFFECTIVE 03/17/2008

ITEM	PART #	DESCRIPTION	QTY
1	00 7348	FLANGE BOLT, 1/2-13 X 1-1/2, GR5	4
2	00 7392	HHC SCREW, 5/8-11 X 4, GR. 8, PLT	1
3	00 7452	SET SCREW, 3/8-16 X 0.5 SQR HD, PLN	2
4	00 7665	NUT, 1/2-13 FLANGE, GR5 STL, PLT	4
5	00 7669	NUT, 5/8-11 NYLOCK - NE, GR. 5 STL	1
6	00 7959	COTTER PIN 5/16" X 3 1/2" PLTD.	2
7	00 8215	FITTING, GREASE, THREAD FORMING	10
8	03 0668	LOCK COLLAR	2
9	03 1782	SADDLE BRKT ASSY, SET, 416/165/25	1
10	03 1795	LIFT ANGLE SA, LR-416/165/25	2
11	03 2010	ANGLE BRACKET, MOUNTING	2
12	032767	CYLINDER, 5 X 21, 2.25 SHAFT	1
13	032897	FRAME WELDMENT, LR-25B	1
14	032927	CYLINDER PIN SHAFT, LR-25B	1

