



TRUCK BODIES & EQUIPMENT INTERNATIONAL, Inc.

Website: www.TBEI.com

E-mail: sales@TBEI.com

Phone: 1-800-869-9162 Rugby

1-800-533-0494 Crysteel

1-800-255-4345 Heil

03 5650

DIRECT MOUNT PUMP INSTALLATION AND OPERATION MANUAL

(Valve/Reservoir: W15-8CR-21 QT
Pump: GP2025)

To Be Filled In By Installer	
Valve Serial #:	_____
Pump Serial #:	_____
Hoist Installation and Operation Manual #:	_____
In Service Date:	_____
Dealer:	_____
Address:	_____
City, State ZIP:	_____
Dealer Phone Number:	_____

Use this manual *ONLY* if installing or operating the pump listed. This manual should be kept in the glove compartment of the truck for reference when needed.

FEATURES: 03 2365, Recycle Valve/21Qt Reservoir, Pump, Tower Control and Cable used with the LR-26B, LR-28A, LR-623, SF-26B, SF-28A, SF-623, P-616, OR P-618.

Original Revision: January 1, 2000

Current Revision: D January 19, 2007

"INTRODUCTION"

This manual contains information necessary for the proper installation and operation of the direct mount power unit listed on the cover. If you have a different power unit, refer to that manufacturer's directions. With proper installation, use, and regular maintenance, this power unit will give many years of trouble free service.

"WARNINGS"

- WARNING:** Installing or operating this hoist without first understanding the proper installation and operation procedures can lead to serious injury or death. **Always** read and understand fully all installation and operation manuals before installing or operating this equipment.
- WARNING:** Being under a raised body can result in serious injury or death should the body unexpectedly descend. **Never** position yourself or allow others to position themselves under a **loaded** body. **Always** prop the **unloaded** body up using the body prop or body props supplied. **Remember** body props are to be used only on an **unloaded** body. When two props are provided, both props must be used.
- WARNING:** Welding, oxy-fuel cutting, or grinding sparks can cause fuel to ignite that in turn can lead to injury or death. **Always** take adequate steps to avoid ignition of fuel from fuel tanks when welding, grinding, or oxy-fuel cutting during equipment installation.
- WARNING:** Heat from the truck's exhaust system can cause hydraulic component failure and may lead to a fire that could cause injury or death. **Always** install equipment in locations where heat from the exhaust system will not damage any hydraulic component.
- WARNING:** Malfunctioning equipment can cause property damage, injury or death. **Always** have faulty equipment repaired before continuing its use. Consult the manufacturer if required.
- WARNING:** Overloading of a truck or trailer can cause vehicle or trailer component damage or an accident which may cause injury or death. **Never** exceed the gross vehicle weight (GVW) or the gross axle weight (GAW) rating of your vehicle or trailer.
- WARNING:** The inadvertent shorting of the vehicle's electrical supply can cause a fire or equipment damage that could lead to injury or death. **Always** disconnect the vehicle battery prior to installing, servicing, or repairing the power unit.

- WARNING:** Damage to brake lines during equipment installation, or installing bolts or equipment in such a way that the line will rub and become damaged can lead to brake failure which can cause an accident and can lead to severe injury or death. **Always** take adequate steps to prevent brake line damage during installation and isolate brake lines from installed equipment.
- WARNING:** Connecting the hoist to a hydraulic system with more pressure (psi) or flow (gpm) than is recommended by the hoist manufacturer can cause the hoist to fail during the dumping of a load. This could lead to damage, serious injury, or death. **Be sure** you have the correct pressure and flow. Consult the manufacturer if you do not know the recommended pressure and flow.
- WARNING:** Adjusting the hydraulic pressure to more than the recommended setting may cause the hoist to fail during the dumping of a load. This could cause damage, serious injury, or death. **Never** adjust the pressure on your own. Consult the manufacturer if the hydraulic pressure is in question. Have only a qualified person set the hydraulic pressure. **Never** adjust the pressure to more than the recommended amount.
- WARNING:** Fluid under pressure can pierce the skin and enter bloodstream, causing serious injury or death. **Always** wear eye protection and protective clothing when working around hydraulic systems.

NOTE: This manual contains descriptions of hydraulic fittings. In describing these fittings special designations are used. These designations and their meanings are as follows:

<u><i>SPECIAL DESIGNATION</i></u>	<u><i>MEANING</i></u>
<i>MPT</i>	<i>MALE PIPE THREAD</i>
<i>FPT</i>	<i>FEMALE PIPE THREAD</i>
<i>MORB</i>	<i>MALE O-RING BOSS THREAD</i>
<i>FORB</i>	<i>FEMALE O-RING BOSS THREAD</i>
<i>HB</i>	<i>HOSE BARB</i>

"SOME FACTS ABOUT THE 'TBEI' DIRECT MOUNT PUMP"

- A. The Commercial Intertech GP2025 series pump is bi-rotational. Therefore, it can be plumbed for a clockwise or counter-clockwise PTO rotation without having to disassemble and reassemble the pump. (Refer to the hydraulic installation instructions of this manual before attempting the hydraulic installation). All pump ports are 1-5/16" FORB.
- B. This pump has an SAE B two bolt flange and a 7/8"-13 tooth SAE B splined shaft. This pump is intended to be directly mounted to the truck PTO, therefore eliminating the sometimes troublesome driveline. This pump will couple directly with a Chelsea brand PTO with a Suffix AK or a Muncie brand PTO with a Suffix D.
- C. The direct mount pump means that the pump is separate from the reservoir. This is an advantage when installing a PTO driven pump on a truck where space is at a minimum. The reservoir can be located just about anywhere and is not limited to a location where the pump can reach the PTO, as is the case for pumps mounted in the reservoir.
- D. The system relief is set at 3200 PSI on the high pressure valve port and 1200 PSI on the low pressure valve port. The hydraulic system is a double acting open center system.

TYPICAL INSTALLATION OF A GP2025 BI-ROTATIONAL PUMP FOR A PTO OF CLOCKWISE ROTATION

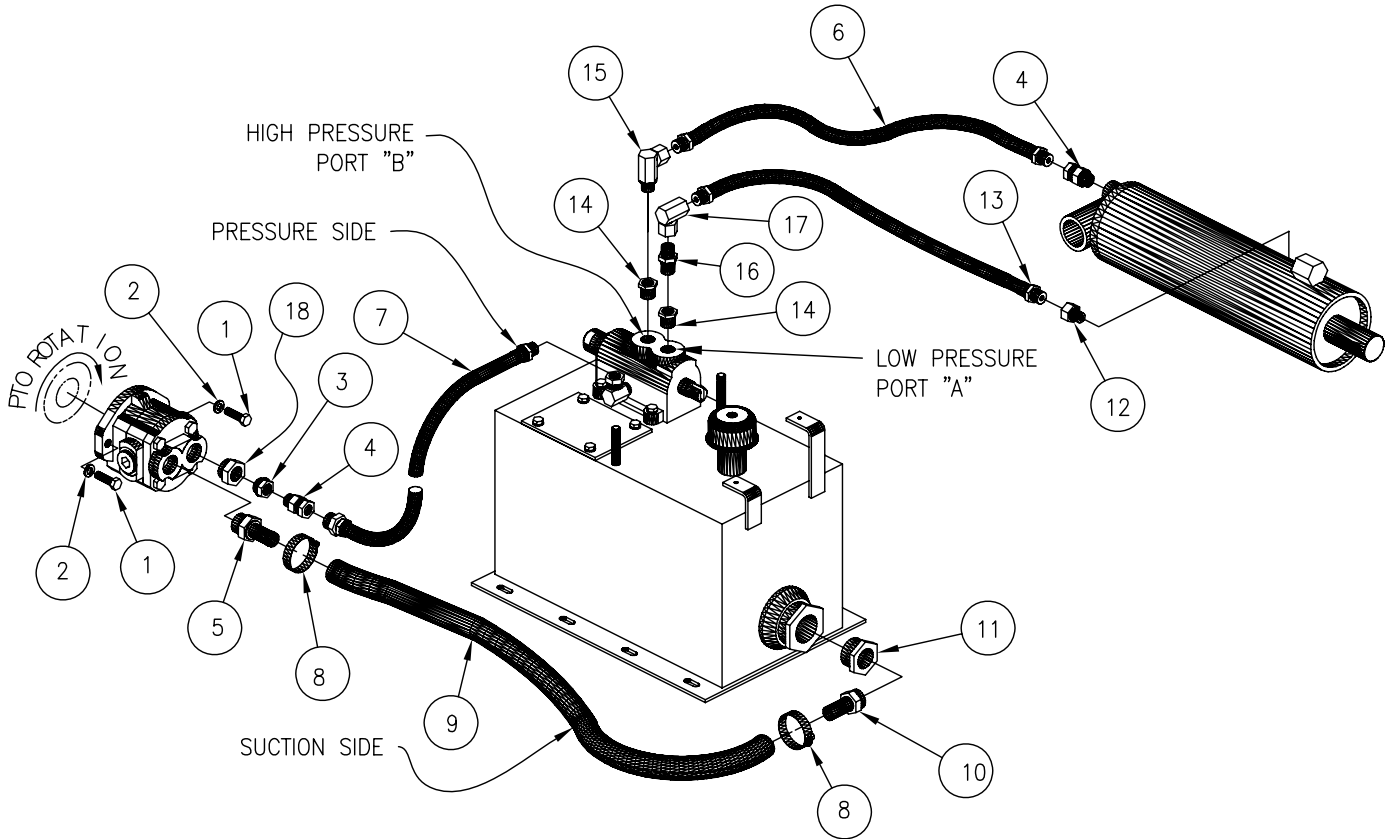

NOTES

1. RESERVOIR IN THIS DRAWING IS SHOWN ROTATED 180° FROM HOW IT WOULD NORMALLY BE POSITIONED IN THE TRUCK FRAME.
2. REFER TO FIGURE 2 IF A GP2025 BI-ROTATIONAL PUMP IS BEING INSTALLED WITH A PTO OF COUNTER-CLOCKWISE ROTATION.

18	00 8110	REDUCER 1 5/16" MORB to 1 1/16" FORB	1
17	00 8263	90° ADAPTER 3/8" FPT to 3/8" FPT SWIVEL	1
16	00 8220	HEX/NIPPLE 3/8" MPT to 3/8" MPT	1
15	00 8231	90° ADAPTER 3/8" MPT to 3/8" FPT SWIVEL	1
14	00 8235	ADAPTER 1/2" MPT to 3/8" FPT	2
13	00 8147	PRESSURE HOSE 3/8" MPT to 3/8" MPT x 7'	1
12	00 8166	ADAPTER 9/16" MORB to 3/8" FPT SWIVEL	1
11	00 8121	ADAPTER 1 1/4" MPT to 1" FPT	1
10	00 8109	ADAPTER 1" HB to 1" MPT	1
9	00 8272	SUCTION HOSE 1" ID x 8' (NO FITTINGS)	1
8	00 7900	HOSE CLAMP	2
7	008327	PRESSURE HOSE 3/8" MPT TO 3/8" MPT x 9'	1
6	00 8133	PRESSURE HOSE 3/8" MPT TO 3/8" MPT x 5'	1
5	00 8106	ADAPTER 1 5/16" MORB to 1" HB	1
4	00 8119	SWIVEL ADAPTER 3/4" MORB to 3/8" FPT	2
3	00 8118	REDUCER 1 1/16" MORB to 3/4" FORB	1
2	00 7744	1/2" LOCK WASHER	2
1	00 7347	1/2" x 1 1/2" HEX CAP SCREW	2
ITEM	PART NUMBER	DESCRIPTION	REQ'D

FIGURE 1

TYPICAL INSTALLATION OF A GP2025 BI-ROTATIONAL PUMP FOR A PTO OF COUNTER-CLOCKWISE ROTATION

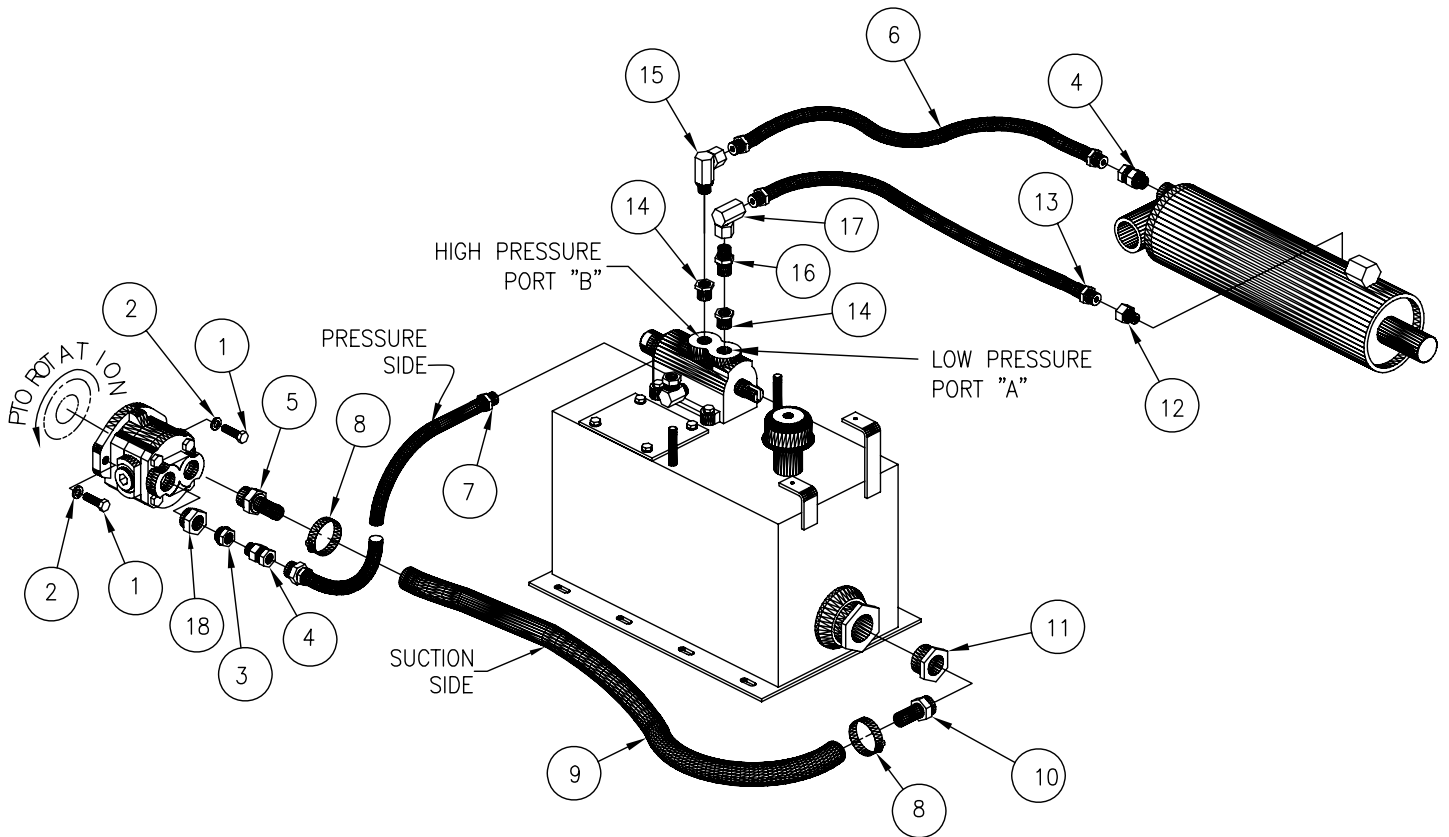

NOTES

1. RESERVOIR IN THIS DRAWING IS SHOWN ROTATED 180° FROM HOW IT WOULD NORMALLY BE POSITIONED IN THE TRUCK FRAME.
2. REFER TO FIGURE 1 IF A GP2025 BI-ROTATIONAL PUMP IS BEING INSTALLED WITH A PTO OF CLOCKWISE ROTATION.

FIGURE 2

18	00 8110	REDUCER 1 5/16" MORB to 1 1/16" FORB	1
17	00 8263	90° ADAPTER 3/8" FPT to 3/8" FPT SWIVEL	1
16	00 8220	HEX/NIPPLE 3/8" MPT to 3/8" MPT	1
15	00 8231	90° ADAPTER 3/8" MPT to 3/8" FPT SWIVEL	1
14	00 8235	ADAPTER 1/2" MPT to 3/8" FPT	2
13	00 8147	PRESSURE HOSE 3/8" MPT to 3/8" MPT x 7'	1
12	00 8166	ADAPTER 9/16" MORB to 3/8" FPT SWIVEL	1
11	00 8121	ADAPTER 1 1/4" MPT to 1" FPT	1
10	00 8109	ADAPTER 1" HB to 1" MPT	1
9	00 8272	SUCTION HOSE 1" ID x 8' (NO FITTINGS)	1
8	00 7900	HOSE CLAMP	2
7	008327	PRESSURE HOSE 3/8" MPT to 3/8" MPT x 9'	1
6	00 8133	PRESSURE HOSE 3/8" MPT to 3/8" MPT x 5'	1
5	00 8106	ADAPTER 1 5/16" MORB to 1" HB	1
4	00 8119	SWIVEL ADAPTER 3/4" MORB to 3/8" FPT	2
3	00 8118	REDUCER 1 1/16" MORB to 3/4" FORB	1
2	00 7744	1/2" LOCK WASHER	2
1	00 7347	1/2" x 1 1/2" HEX CAP SCREW	2
ITEM	PART NUMBER	DESCRIPTION	REQ'D

"INSTALLATION"

The following step-by-step instructions are to be followed as a general guideline when installing the direct mount pump and remote reservoir.

NOTE: All 3/8" diameter bolts used in this installation must be torqued to 37 ft-lb., unless otherwise noted. All 1/2" diameter bolts used in this installation must be torqued to 90 ft-lb., unless otherwise noted.

1. Locate the reservoir (within reach of the 9' hose) after installing the hoist. A good location for the reservoir is on the outside of the chassis frame, on the left or right side, directly behind the cab.
2. Position, then clamp each of the two reservoir brackets to the frame. Drill two 17/32" dia. holes through both the reservoir brackets and the truck frame. Fasten each with two 1/2" x 2-1/2" hex cap screws, two 1/2" lock washers, and two 1/2" hex nuts.

NOTE: To prevent frame failure, position the two 17/32" dia. holes for each reservoir bracket within the center 1/3 of the truck frame web. **NEVER WELD TO THE CHASSIS FRAME!**

3. Attach the reservoir to the pump brackets installed in Step #2, using four 3/8" x 1-1/4" hex cap screws, eight 3/8" flat washers, four 3/8" lock washers, and four 3/8" hex nuts.
4. Install the PTO onto the truck transmission, using the instructions included with the PTO.
5. Determine if the PTO output collar rotates in a clockwise or counter-clockwise direction. Refer to Figure 1 or Figure 2.
6. Install the hydraulic fittings into the pump ports. Refer to Figure 1 or Figure 2. If it is necessary to move the steel port plugs from the side ports to the rear ports, retighten each steel port plug to 133 ft-lb.
7. Position the pump's shaft into the PTO and secure the pump to the PTO with two 1/2" x 1-1/2" hex cap screws and lock washers.
8. Refer to Figure 1 or Figure 2 to complete the hydraulics installation.

NOTE: When installing the 3/8" MPT to 3/8" MPT nipple into the valve work port, be sure that the nipple end that attaches to the 3/8" FPT to 3/8" FPT swivel elbow has an internal chamfer, otherwise this joint will leak.

9. Install the remote valve shift cable and remote valve shifter using the "Cable to Latch Lock Head Installation Instruction Sheet" included with the Reservoir/Valve Assembly.

10. Fasten the remote valve shifter bracket to the floor (floor mounting hardware not included) in a convenient location.
11. Mount the remote valve shifter and shifter cover to the remote valve shifter bracket, using three 5/16" x 2-1/2" hex cap screws and three 5/16" hex oval lock nuts. Refer to Figure 3.
12. Install the Double Action Hoist Decal to the remote valve shifter bracket. Refer to Figure 3.

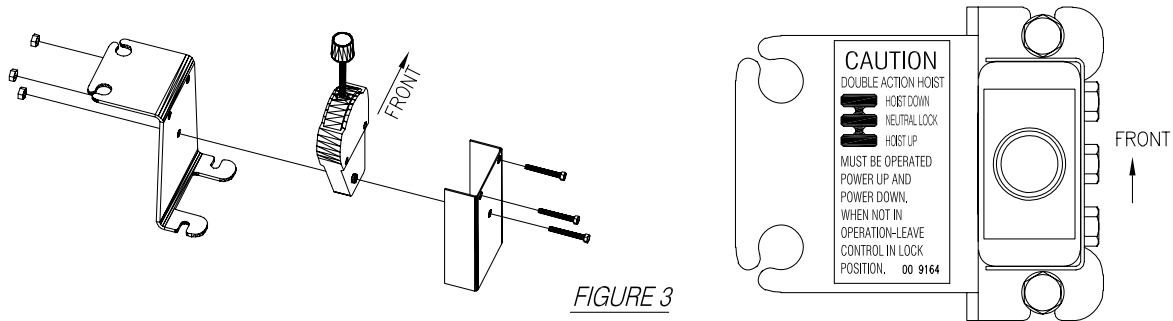

13. Fill the reservoir with oil. The reservoir will require 22 quarts of oil on the initial fill. If either a Model LR-28A, SF-28A, or P-618 is installed, additional oil must be added after the initial 22 quarts have been added. More specifically, five additional quarts will be required by the LR-28A, SF-28A, or P-618. To add the required additional oil after the initial fill, partially raise the hoist and secure the body up with a body prop or body props. Then add the additional five quarts of oil to the reservoir.

IMPORTANT: For all season use, **Dextron II Type A** automatic transmission fluid is recommended to protect all hydraulic components. For operation over 30° F, a good grade of hydraulic oil, such as **Texaco's Regal R & O 32**, can be used. **ALWAYS** use clean oil.

WARNING: Do not attempt to run the pump without oil, as it will fail in a very short time! Before operating the hoist, read and understand the operation section of this manual. Do not perform any operation or maintenance under a raised truck body without first blocking the unloaded body up with a body prop or body props.

"PTO PUMP OPERATION"

NOTE: To ensure long service and safety from your hoist, it is important that the following procedure is followed every time the hoist is operated.

1. Engage the PTO from cab.

NOTE: **NEVER** operate the pump at more than 1800 RPM PTO speed. The rate of your PTO speed and engine speed will depend on the gear ratio in the PTO drive installed on your truck transmission.

2. Move the shifter lever to the "POWER UP" position. This will raise the hoist. Adjust the engine speed to obtain the speed of lift you desire.
3. When the hoist reaches its raised limit, the pump will bypass. Care should be taken not to let the pump bypass for long periods, as it puts stress on the whole hydraulic system. To prevent the pump from bypassing, simply move the shifter lever to the "LOCK" position (center). When the shifter lever is centered, the hoist will stop moving and hold its position.
4. To lower the hoist, move the shifter lever to the "POWER DOWN" position.
5. To lock the hoist against the truck frame when the hoist is in the down position, move the shifter lever to the "POWER DOWN" position. When you hear that the pump is bypassing, simply move the shifter lever to the "LOCK" position (center).
6. Before transporting the truck, disengage the PTO.

NOTE: Failure to disengage the PTO can cause damage to the hydraulic pump.