

INDUSTRIAL PARK  
515 1ST STREET NORTH EAST  
RUGBY, ND 58368

**03 5804**

# *LR-26B, LR-27B, LR-28A, or LR-623 INSTALLATION AND OWNER'S MANUAL*

*To Be Filled In By Installer*

*Hoist Installed:* \_\_\_\_\_

*Hoist Serial #:* \_\_\_\_\_

*Pump Installation & Operation Manual #:* \_\_\_\_\_

*In-Service Date:* \_\_\_\_\_

*Dealer:* \_\_\_\_\_

*Address:* \_\_\_\_\_  
\_\_\_\_\_

*Dealer Phone#:* \_\_\_\_\_

Use this manual ONLY if installing or operating an LR-26B, LR-27B, LR-28A, or LR-623 hoist. If installing or operating a model SF-26B, SF-28A, or SF-623 Sub-frame hoist, refer to manual #03 6077. This manual should be kept in truck glove compartment for reference when needed.

Features LR-26B(03 1440),LR-27B(03 1484),LR-28A(03 1439),LR-623(03 2040)

***First Edition: August 1, 1996***  
***Latest Edition: 7 (October 31, 2001)***



**IMPORTANT FACTS ABOUT THIS MANUAL**

The Rugby® model SF-26B, SF-28A, and SF-623 hoists are installed with a sub-frame. The model LR-26B, LR-27B, LR-28A, and LR-623 hoists are installed without a sub-frame. If you are installing an LR-26B, LR-27B, LR-28A, and LR-623, this manual (Part #03 5804) is the correct manual. If you are installing an SF-26B, SF-28A, or SF-623, this manual (part #03 5804) is the incorrect manual to use. The correct manual (Part #03 6077) should be obtained and used. This manual (part #03 5804) covers only the installation of the hoist itself and the rear hinge.

This manual **does not** cover the installation and operation of the body prop or body props. The installation and operation of the body prop or body props is covered in the manual #03 6034. The #03 6034 manual is included in every LR-26B, LR-27B, LR-28A, or LR-623 application sold by Rugby Manufacturing Co.

This manual (part #03 5804) **does not** cover the installation and operation of the hydraulic system. There are four different types of hydraulic systems available for some or all of the hoist models (LR-26B, LR-27B, LR-28A, or LR-623).

The four types of hydraulic systems and their respective installation and operation manuals are listed below:

Installation and Operation Manual Part Number	Type of Hydraulic System
03 5679	Drive shaft driven pump with mid-latch cable
03 5650	Direct Mount Pump with tower control
03 5669	Electric double acting with push button control
03 5670	Electric single acting with push button control

Depending on the type of hydraulic system purchased, one of the above manuals will be included in every LR-26B, LR-27B, LR-28A, or LR-623 sold by Rugby Manufacturing Co. Before installing one of the before mentioned hoists, be sure you have the proper manuals to do the job. If you do not have the correct manuals contact Rugby Manufacturing Co.

## **"CAUTION"**

The hydraulic system supplied with a given hoist manufactured by Rugby Manufacturing Co. is made up of components (pump, valves, reservoir, hoses, cylinder, etc.) that are designed to be compatible with each other.

If you substitute hydraulic components, it is your responsibility to BE SURE they are compatible with the other components supplied by Rugby Manufacturing Co. Incompatible hydraulic components may cause failure of the hoist which in turn could damage the truck, damage other property, and cause human injury or death.

All Rugby Manufacturing Co.'s liability and warranty for a given hoist will be voided if it is determined by Rugby Manufacturing Co. that substituted hydraulic components were used that were incompatible with those supplied by Rugby Manufacturing Co.

Several hoist hydraulic parameters are given in the following table. These parameters are given as a general guide. To ensure component compatibility, consult Rugby Manufacturing Co.

<u><b>HOIST MODEL</b></u>	LR-27B	LR-26B LR-28A LR-623
<u><b>"MAXIMUM"</b></u> HYDRAULIC FLOW RATE (GPM)	12 GPM	9GPM
<u><b>"MAXIMUM"</b></u> PRESSURE FOR RAISING PORTION OF DUMP CYCLE (PSI)	2350 PSI	3200 PSI
<u><b>"MAXIMUM"</b></u> PRESSURE FOR LOWERING PORTION OF DUMP CYCLE (PSI)	750 PSI	1000 PSI

The following step-by-step instructions are to be followed as a general guideline when installing the LR-26B, LR-27B, LR-28A, or LR-623 hoist assembly:

**Warning:** Welding, oxy-fuel cutting, or grinding sparks can cause fuel to ignite which in turn can lead to injury or death. "**Always**" take adequate steps to avoid ignition of fuel from fuel tanks when welding, grinding, or oxy-fuel cutting during equipment installation.

**Warning:** Heat from the truck's exhaust system can cause hydraulic component failure and may lead to a fire which could cause injury or death. "**Always**" install equipment in locations where heat from the exhaust system will not damage any hydraulic component.

**Warning:** Being under a raised body can result in serious injury or death should the body inadvertently descend. "**Never**" position yourself or allow others to position themselves under a "**loaded**" body. "**Always**" prop the "**unloaded**" body up using the body prop or body props supplied. "**Remember**", body props are to be used only on an unloaded body.

**Warning:** Malfunctioning equipment can cause property damage, injury or death. "**Always**" have faulty equipment repaired before continuing its use. If required, consult the manufacturer.

**Warning:** Overloading of a truck can cause truck component damage, or an accident which may cause injury or death. "**Never**" exceed the gross vehicle weight (GVW) or the gross axle weight (GAW) rating of your vehicle.

**Warning:** Not installing or operating equipment correctly can cause component damage, or an accident which may cause injury or death. "**Always**" install and operate equipment in accordance with manufacturer's instructions. Read and understand this manual fully before proceeding.

*FIGURE 1*

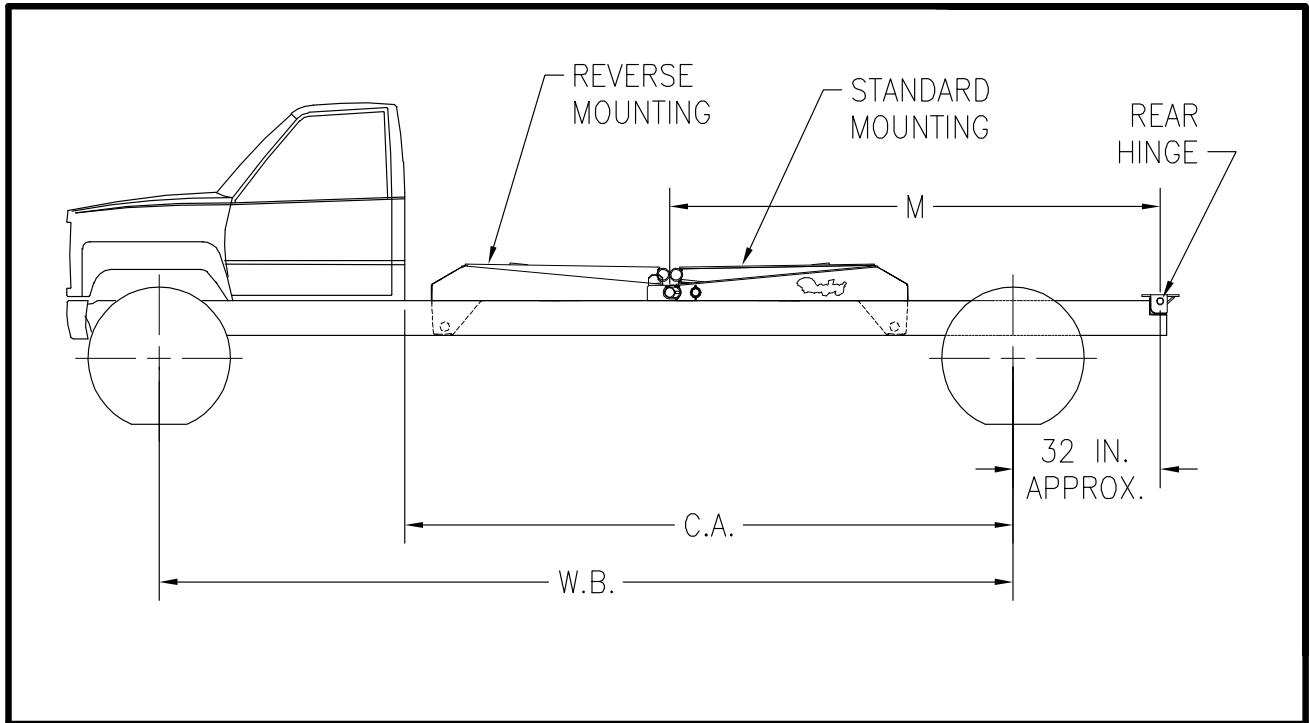

**ABOUT RUGBY® HOISTS**

*Capacities are based on water level, non-diminishing loads. Because of the variations in truck equipment and cab axles (CA), the data contained in the following data sheets are provided only as a general guide. The following values for capacities are in accordance with NTEA rating procedures.*

**MODEL:** LR-26B  
**DUMP CLASS** 50  
**CONVERSION CLASS:** E

6" dia. piston; 20" stroke; 102" to 120" CA; 13' to 16' box; 40° to 50° dump angle; 7 1/4" mounting height; 6" long beams recommended.

**LR-26B CONVERSION APPLICATION**

<b>BODY LENGTH</b>	<b>REAR OVERHANG</b>	<b>CAPACITY 40° DUMP</b>	<b>CAPACITY 45° DUMP</b>	<b>CAPACITY 50° DUMP</b>
13'	42"	26 Ton	23 Ton	21 Ton
13'	30"	19 Ton	17 Ton	15 Ton
13'	24"	17 Ton	15 Ton	14 Ton
14'	42"	22 Ton	20 Ton	18 Ton
14'	36"	19 Ton	17 Ton	15 Ton
14'	30"	17 Ton	15 Ton	14 Ton
15'	48"	22 Ton	20 Ton	18 Ton
15'	42"	19 Ton	17 Ton	15 Ton
15'	36"	17 Ton	15 Ton	14 Ton
16'	48"	19 Ton	17 Ton	15 Ton
16'	42"	17 Ton	15 Ton	14 Ton

**LR-26B DUMP APPLICATION**

<b>BODY LENGTH</b>	<b>OVERHANG</b>	<b>CAPACITY 50° DUMP</b>
10'	12"	15 Ton
11'	12"	14 Ton
12'	12"	12 Ton

<b>REVERSE MOUNTING</b>	
<b>DUMP ANGLE</b>	<b>M dimension</b>
40°	109"
45°	98"
50°	88"

<b>STANDARD MOUNTING</b>	
<b>DUMP ANGLE</b>	<b>M dimension</b>
40°	111"
45°	100"
50°	90"

LR-26B, LR-27B, LR-28A, or LR-623

Stock No. 03 5804

Page 7 of 19

**MODEL:** LR-27B

**DUMP CLASS** 50

**CONVERSION CLASS** E

7" dia. piston; 20" stroke; 102" to 120" CA; 13' to 16' box; 40° to 50° dump angle; 7 1/4" mounting height; 6" long beams recommended.

**LR-27B CONVERSION APPLICATION**

<b>BODY LENGTH</b>	<b>REAR OVERHANG</b>	<b>CAPACITY 40° DUMP</b>	<b>CAPACITY 45° DUMP</b>	<b>CAPACITY 50° DUMP</b>
13'	42"	26 Ton	23 Ton	21 Ton
13'	30"	19 Ton	17 Ton	15 Ton
13'	24"	17 Ton	15 Ton	14 Ton
14'	42"	22 Ton	20 Ton	18 Ton
14'	36"	19 Ton	17 Ton	15 Ton
14'	30"	17 Ton	15 Ton	14 Ton
15'	48"	22 Ton	20 Ton	18 Ton
15'	42"	19 Ton	17 Ton	15 Ton
15'	36"	17 Ton	15 Ton	14 Ton
16'	48"	19 Ton	17 Ton	15 Ton
16'	42"	17 Ton	15 Ton	14 Ton

**LR-27B DUMP APPLICATION**

<b>BODY LENGTH</b>	<b>OVERHANG</b>	<b>CAPACITY 50° DUMP</b>
10'	12"	15 Ton
11'	12"	14 Ton
12'	12"	12 Ton

<b>REVERSE MOUNTING</b>	
<b>DUMP ANGLE</b>	<b>M dimension</b>
40°	109"
45°	98"
50°	88"

<b>STANDARD MOUNTING</b>	
<b>DUMP ANGLE</b>	<b>M dimension</b>
40°	111"
45°	100"
50°	90"

**MODEL:** LR-28A  
**DUMP CLASS:** 60  
**CONVERSION CLASS:** F

6" dia. piston; 28" stroke; 114" to 138" CA; 16' to 18' box; 40° to 50° dump angle; 8 1/4" mounting height; 7" long beams recommended.

**LR-28A CONVERSION APPLICATION**

<b>BODY LENGTH</b>	<b>REAR OVERHANG</b>	<b>CAPACITY 40° Dump</b>	<b>CAPACITY 45° Dump</b>	<b>CAPACITY 50° Dump</b>
13'	12"	N/A	16 Ton	15 Ton
14'	24"	N/A	18 Ton	16 Ton
15'	36"	N/A	20 Ton	18 Ton
15'	30"	N/A	18 Ton	16 Ton
16'	42"	N/A	20 Ton	18 Ton
16'	36"	20 Ton	18 Ton	16 Ton
17'	48"	22 Ton	20 Ton	18 Ton
17'	42"	20 Ton	18 Ton	16 Ton
17'	36"	18 Ton	16 Ton	15 Ton
18'	42"	18 Ton	16 Ton	15 Ton
18'	48"	20 Ton	18 Ton	16 Ton

<b>REVERSE MOUNTING</b>	
<b>DUMP ANGLE</b>	<b>M dimension</b>
40°	144"
45°	129"
50°	118"

<b>STANDARD MOUNTING</b>	
<b>DUMP ANGLE</b>	<b>M dimension</b>
40°	146"
45°	131"
50°	120"



LR-26B, LR-27B, LR-28A, or LR-623

Stock No. 03 5804

Page 9 of 19

**MODEL:** LR-623  
**DUMP CLASS:** 50  
**CONVERSION CLASS:** F

6" dia. piston; 23" stroke; 10' to 18' box; 40° to 50° dump angle; 8" mounting height; 7" long beams recommended.

**LR-623 CONVERSION APPLICATION**

<b>BODY LENGTH</b>	<b>REAR OVERHANG</b>	<b>CAPACITY 40° Dump</b>	<b>CAPACITY 45° Dump</b>	<b>CAPACITY 50° Dump</b>
10'	6"	N/A	19 Ton	18Ton
11'	18"	N/A	22 Ton	20 Ton
12'	6"	18 Ton	16 Ton	14 Ton
13'	18"	20 Ton	17 Ton	16 Ton
13'	24"	22 Ton	19 Ton	18 Ton
13'	42"	N/A	29 Ton	27 Ton
14'	18"	18 Ton	16 Ton	14 Ton
14'	30"	22 Ton	19 Ton	18 Ton
14'	36"	25 Ton	22 Ton	20 Ton
16'	18"	15 Ton	13 Ton	12 Ton
16'	24"	16 Ton	14 Ton	13 Ton
16'	42"	22 Ton	19 Ton	18 Ton
18'	18"	13 Ton	11 Ton	10 Ton
18'	30"	15 Ton	13 Ton	12 Ton
18'	42"	18 Ton	16 Ton	14 Ton

<b>REVERSE MOUNTING</b>	
<b>DUMP ANGLE</b>	<b>M dimension</b>
40°	117.75"
45°	105.25"
50°	95.25"

<b>STANDARD MOUNTING</b>	
<b>DUMP ANGLE</b>	<b>M dimension</b>
40°	119.0"
45°	106.5"
50°	96.5"

**LR-26B, LR-27B, LR-28A, & LR-623 ASSEMBLY INSTRUCTIONS**

**NOTE:** If you are installing a SF-26B, SF-28A, or SF-623 refer to manual with Part #03 6077.

1. Mark the location for the rear hinge. This location should be immediately behind a truck cross member, approximately 32" behind the center of the rear axle on single axle trucks. Refer to Fig. #1 and the charts for the specific hoist model you are installing.

**NOTE:** If a distance of 38" is exceeded between the rear hinge and the center of the rear axle, additional reinforcement of the truck frame will be required.

2. Cut a notch in each truck chassis frame rail as illustrated in Fig. #2.
3. Position the rear hinge angle in the notch cut in Step 2. The rear hinge angle is 38 1/16" wide and should be centered side to side in the notch as illustrated in Fig. #3. Weld the rear hinge angle to each of the truck chassis frame rails.

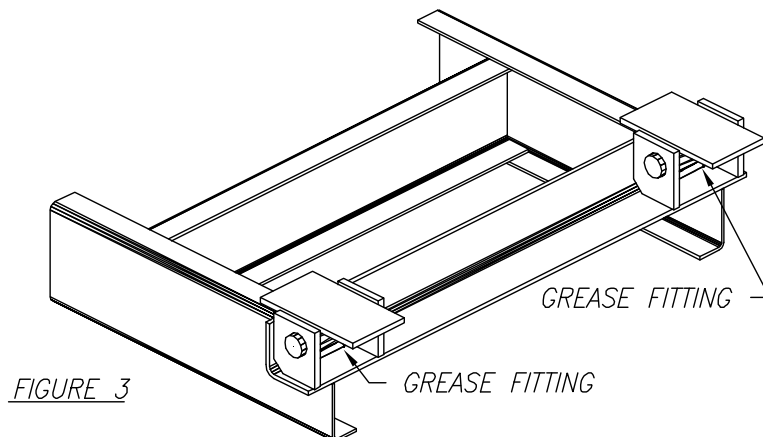
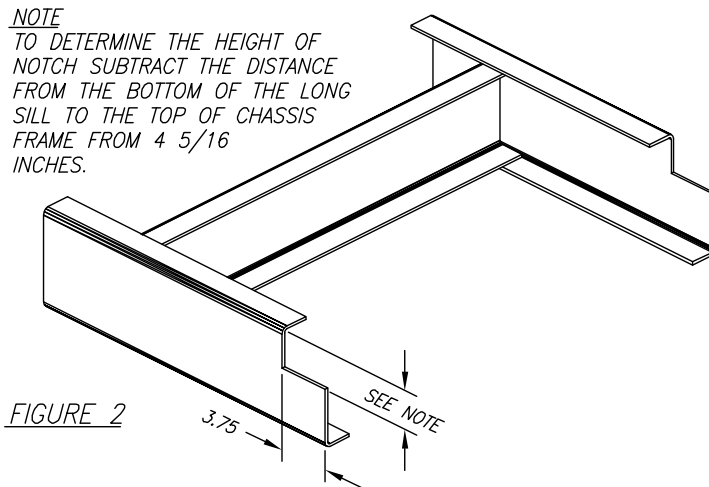

**NOTE:** This hinge assembly is designed for a truck longsill spacing of 34" and is not recommended for any other width.

4. Locate the hoist on the truck frame making sure to center the hoist right and left and to square the hoist with the truck frame. The "LR" series is designed to be positioned as shown in Fig. #1. The distance between the rear hinge center and the saddle center (Fig. #1) is referred to as the "M" dimension. In table A, the "M" dimensions for several common dump angles are tabulated.

**WARNING:** During the first degrees of the dump cycle, the hoist lower link will move forward if in the standard mounting configuration. The lower link will move rearward if in the reverse mounting configuration. Therefore, it is important to keep the areas illustrated in Fig. #4 open to allow this hoist movement. Failure to do this will cause the hoist to not operate as intended and may damage the hoist and/or other truck components.

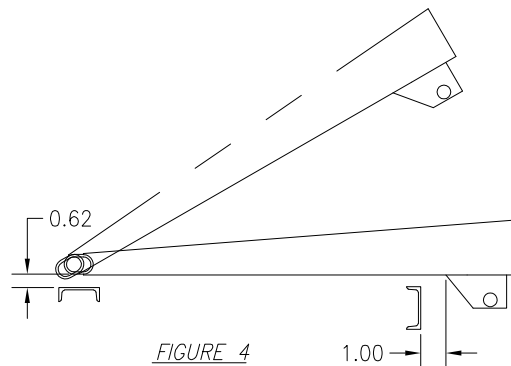

**NOTE:** Moving the hoist along the truck frame will effect the hoist's performance. A forward movement will reduce the dump angle and will increase capacity, while a rearward movement will increase the dump angle and decrease capacity.

**NOTE:** If hoist saddle brackets (shown in Fig. #5) need to be adjusted so as to set flat on the truck frame, loosen the 1/2" x 1 1/2" hex cap screw illustrated in Fig. #5. This will free the saddle brackets so they can be rotated. Once the saddle brackets are in place, retighten the cap screw. (Screw will be removed in step 12).

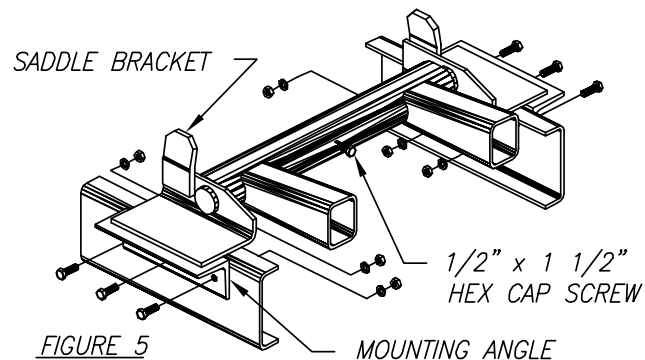

5. Slide a lock collar onto each lifting shaft. Slide a lifting shaft, with collar, into each end of the hoist lifting tube (Fig. #6).

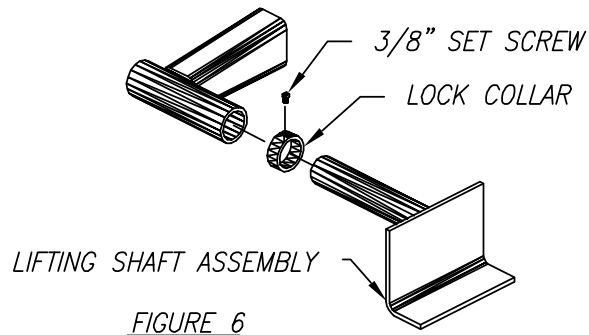

6. When the hoist is positioned, place a mounting angle under each side of the saddle. Secure each mounting angle to the truck frame by drilling three 17/32" dia. holes and installing three 1/2" x 1 1/2" hex cap screws, three 1/2" lock washers and three 1/2" hex nuts (Fig. #5).
7. Weld each mounting angle to the corresponding hoist saddle bracket (Fig. #5).

**NOTE:**        **Do not** weld the hoist saddle brackets to the truck frame.

**NOTE:**        The hoist saddle brackets must sit directly on the truck frame. If rivet interference is encountered, countersink the rivet heads into the hoist saddle brackets.

8. Position and secure the liner (sleeper) to the truck frame. The LR-26B & LR-27B hoist requires at least 7 1/4" of clearance above the truck frame. The LR-28A requires 8 1/4" clearance. The LR-623 requires 8" clearance. As an example, if the truck body to be mounted has 6" long beams, a liner (sleeper) of 1 1/4" would be required to gain enough room (7 1/4") to mount a LR-26B or LR-27B hoist.
9. Position the body with the long beams (just long beams if they are separate from body) onto the truck frame.

**NOTE:**        A clearance of at least 2" is required between the truck cab and the closest point on the truck body.

10. Attach each rear hinge bracket to each long beam by welding all edges where the rear hinge bracket contacts the long beam.
11. Position a lifting shaft assembly next to each channel long beam. Refer to Fig. 7 or 8 depending on which model of hoist is being installed and what size long beams are being used. Four 1/2" X 2 1/2" flats are supplied for each LR-26B, LR-27B, LR-28A, and LR-623. Weld each of two lifting shaft assemblies to each body long beam. With the shafts secured, slide the lock collars against the hoist lifting tube and lock them there by tightening the set screws. Refer to Fig. 6.

12. Remove the 1/2" X 1 1/2" hex cap screw from the saddle tube, refer to Fig. 5. Plug hole with the plastic plug supplied.

**WARNING:** After the hoist is fastened to both the truck frame and the body, it is important to remove the 1/2" X 1 1/2" hex cap screw, as failure to do this will prevent the before mentioned "anti-kick up device" from functioning, and could cause damage to the hoist and/or other truck components.

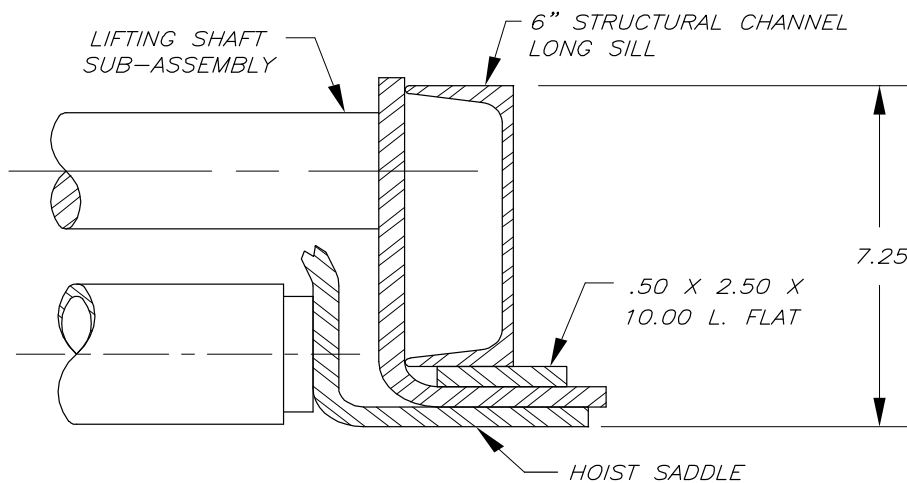

1. LR26B & LR27B HOIST TO BODY ATTACHMENT DETAIL FOR 6" STRUCTURAL CHANNEL LONG SILLS AND 7.25" MOUNTING HEIGHT.

FIGURE 7

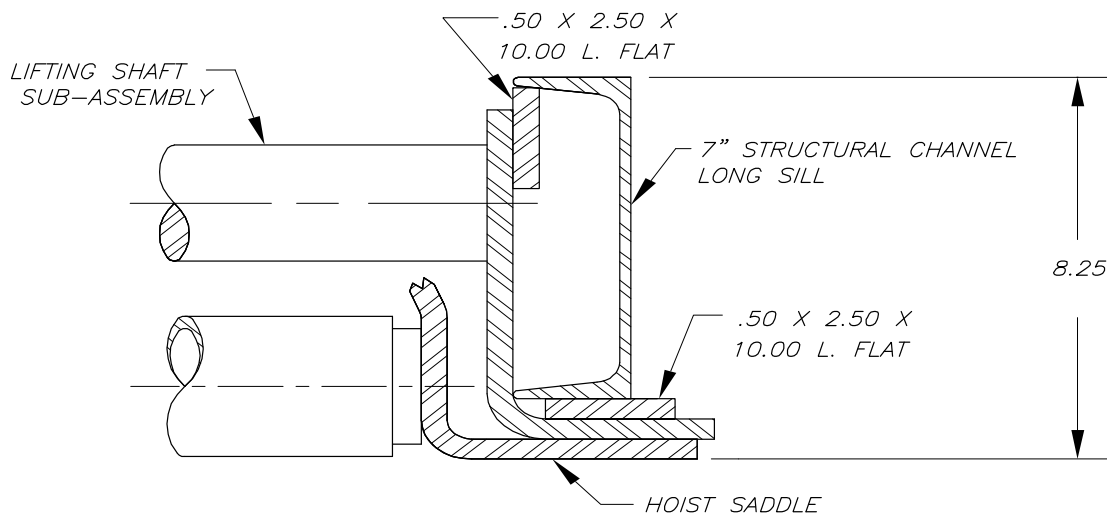

1. LR28A & LR-623 HOIST TO BODY ATTACHMENT DETAIL FOR 7" STRUCTURAL CHANNEL LONG SILLS AND 8.25" MOUNTING HEIGHT.

FIGURE 8

LR-26B, LR-27B, LR-28A, or LR-623

Stock No. 03 5804

Page 14 of 19

13. Install body prop or body props per separate instructions (Part #03 6034) included with this hoist.

**NOTE:** Before operating the hoist, read and understand the correct operation procedures for the type of hydraulic system this hoist has. Refer to page 2 of the manual for the correct operation manual part number.

**WARNING:** If it is necessary to work on the hoist or body while in the raised position, **ALWAYS** work under an unloaded body securely blocked up with body prop or body props.

**LUBRICATION:** Install and grease the 10 grease fittings in the hoist frame itself. Refer to Fig. #9 for grease fitting locations for LR-26B, LR-27B, LR-28A, or LR-623.

Install and grease the two grease fittings in the truck rear hinge. Refer to Fig. #3 for locations of these grease fittings.

All grease fittings should be greased periodically or at least every time the truck itself is greased.

Check the oil level in the pump reservoir every time the oil is changed in the truck engine. **REMEMBER TO KEEP THE OIL CLEAN.** An annual oil change can prevent contaminants from ruining your pump and hoist cylinder.

LR-26B, LR-27B, LR-28A, or LR-623  
Stock No. 03 5804  
Page 15 of 19

Fig. #9 Models LR-26B, LR-27B, LR-28A, & LR-623 Grease Fitting Locations

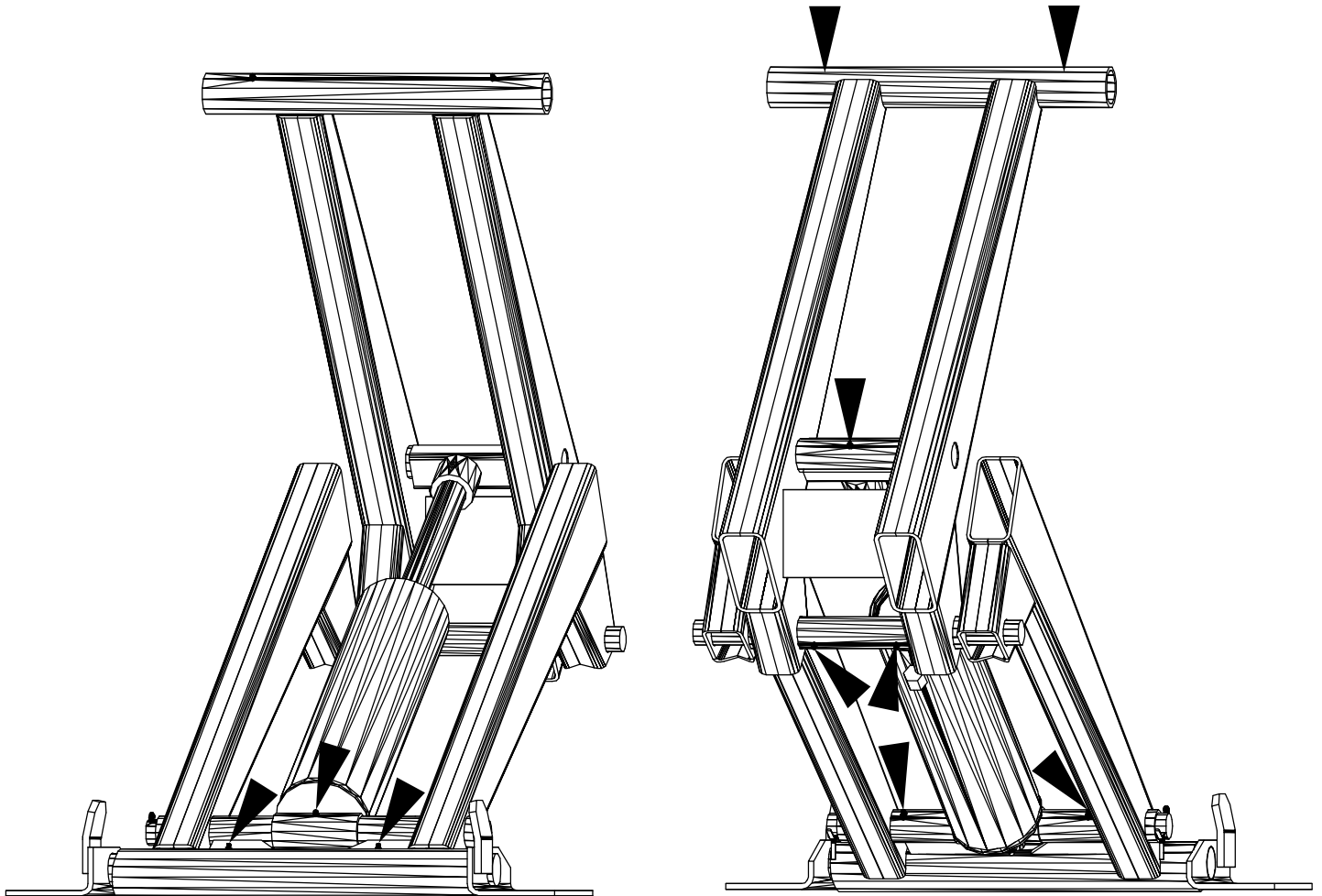

LR-26B, LR-27B, LR-28A, or LR-623

Stock No. 03 5804

Page 16 of 19

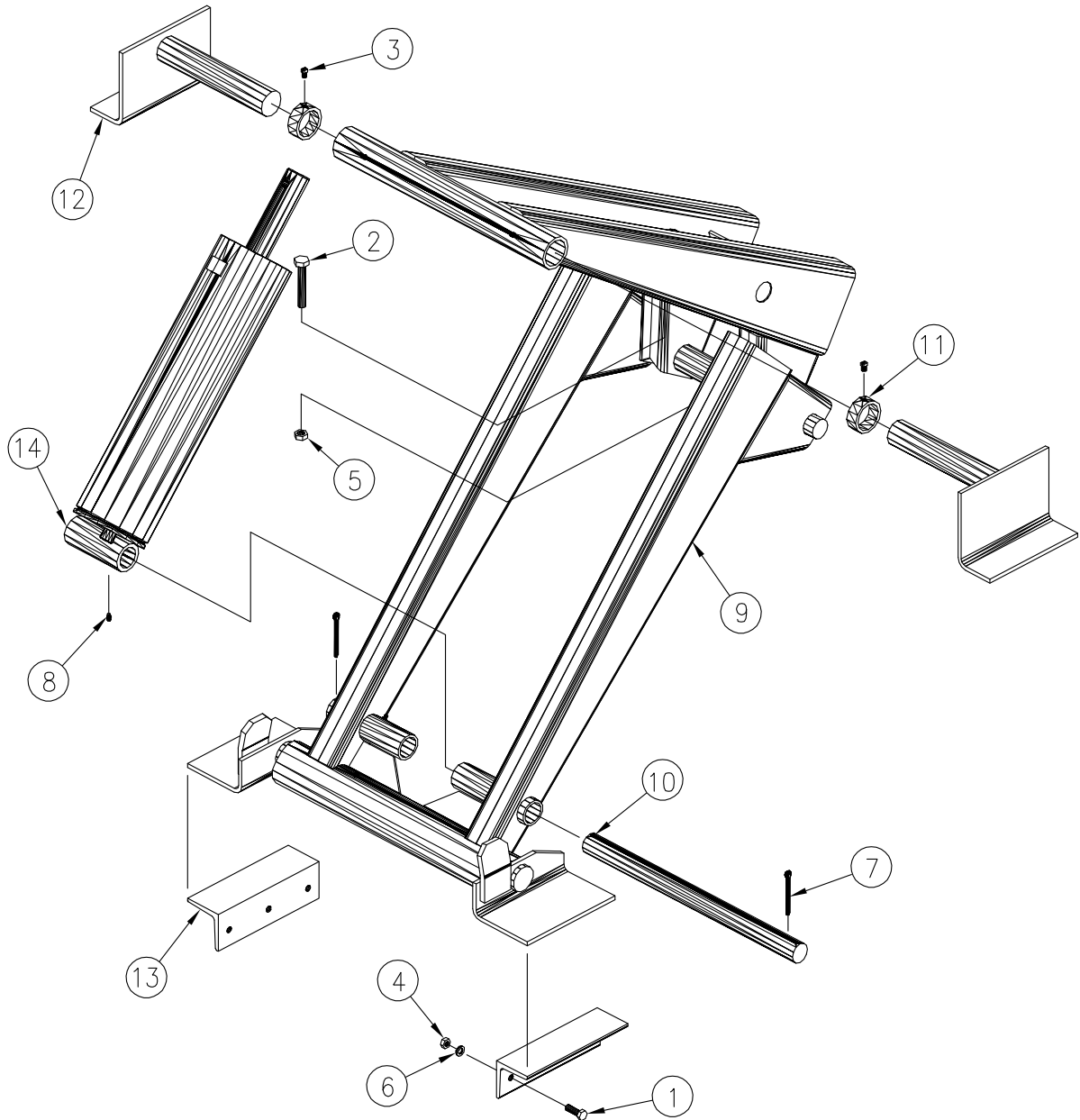

FIGURE 10 LR-26B HOIST

7	00 7959	5/16" x 3 1/2" COTTER PIN	2	14	03 2551	6" x 20" CYLINDER	1
6	00 7744	1/2" LOCK WASHER	6	13	03 0709	MOUNTING ANGLE	2
5	00 7669	5/8" HEX LOCKNUT	1	12	03 1476	LIFTING SHAFT ASSEMBLY	2
4	00 7662	1/2" HEX NUT	6	11	03 3291	LOCK COLLAR	2
3	00 7452	3/8" SET SCREW	2	10	03 0744	CYLINDER PINNING SHAFT	1
2	00 7392	5/8 x 4 HEX CAP SCREW Gr. 8 PLTD	1	9	03 1715	FRAME ASSEMBLY	1
1	00 7347	1/2 x 1 1/2 HEX CAP SCREW Gr. 5 PLTD	6	8	00 8215	GREASE FITTING 1/4" THREAD FORMING	10
ITEM	PART NUMBER	DESCRIPTION	REQ'D	ITEM	PART NUMBER	DESCRIPTION	REQ'D



LR-26B, LR-27B, LR-28A, or LR-623

Stock No. 03 5804

Page 17 of 19

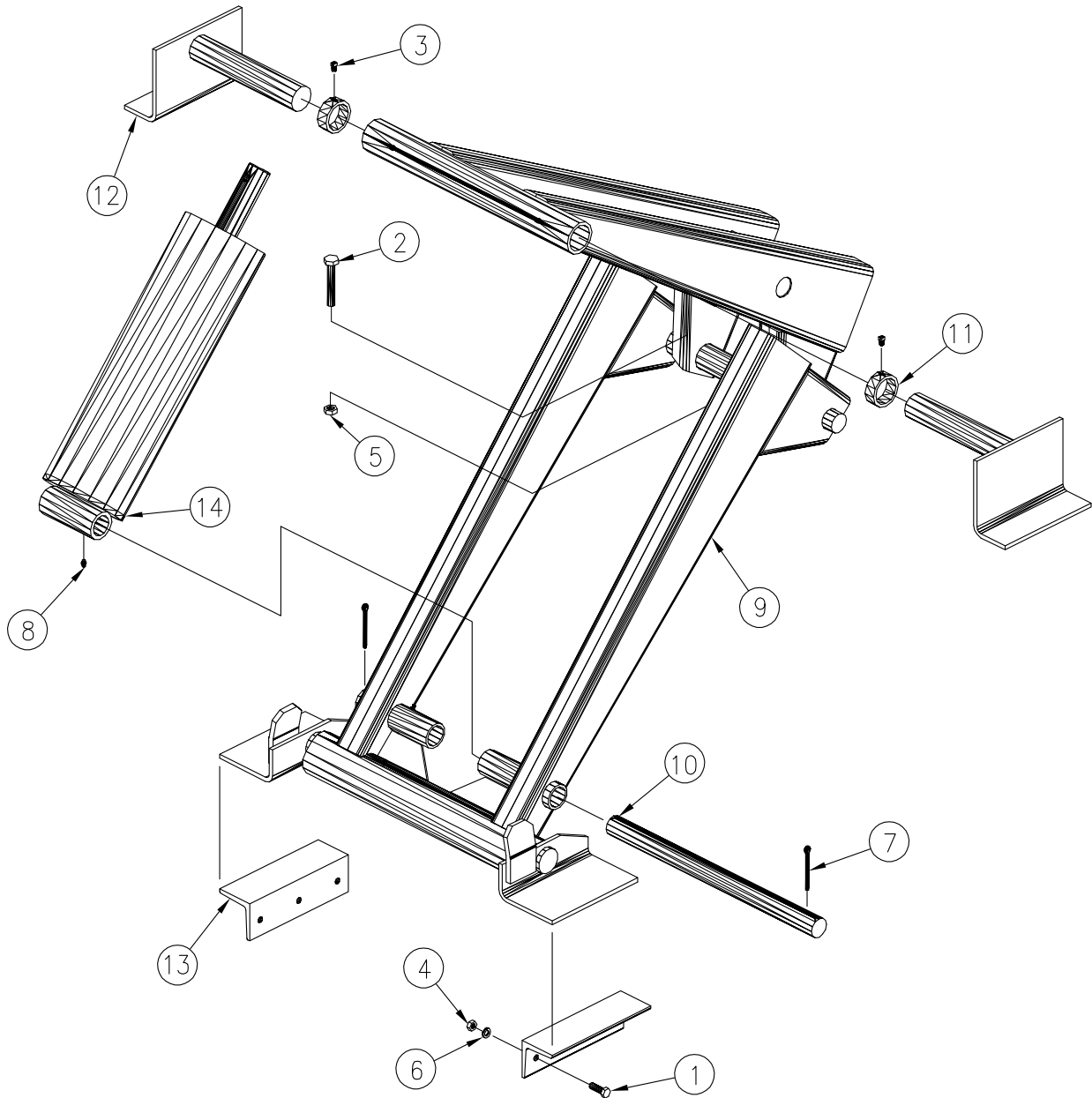

FIGURE 11 LR-27B HOIST

7	00 7959	5/16" x 3 1/2" COTTER PIN	2	14	10 0709	7" x 20" CYLINDER	1
6	00 7744	1/2" LOCK WASHER	6	13	03 0709	MOUNTING ANGLE	2
5	00 7669	5/8" HEX LOCKNUT	1	12	03 1476	LIFTING SHAFT ASSEMBLY	2
4	00 7662	1/2" HEX NUT	6	11	03 3291	LOCK COLLAR	2
3	00 7452	3/8" SET SCREW	2	10	03 0744	CYLINDER PINNING SHAFT	1
2	00 7392	5/8 x 4 HEX CAP SCREW Gr. 8 PLTD	1	9	03 1715	FRAME ASSEMBLY	1
1	00 7347	1/2 x 1 1/2 HEX CAP SCREW Gr. 5 PLTD	6	8	00 8215	GREASE FITTING 1/4" THREAD FORMING	10
ITEM	PART NUMBER	DESCRIPTION	REQ'D	ITEM	PART NUMBER	DESCRIPTION	REQ'D

LR-26B, LR-27B, LR-28A, or LR-623

Stock No. 03 5804

Page 18 of 19

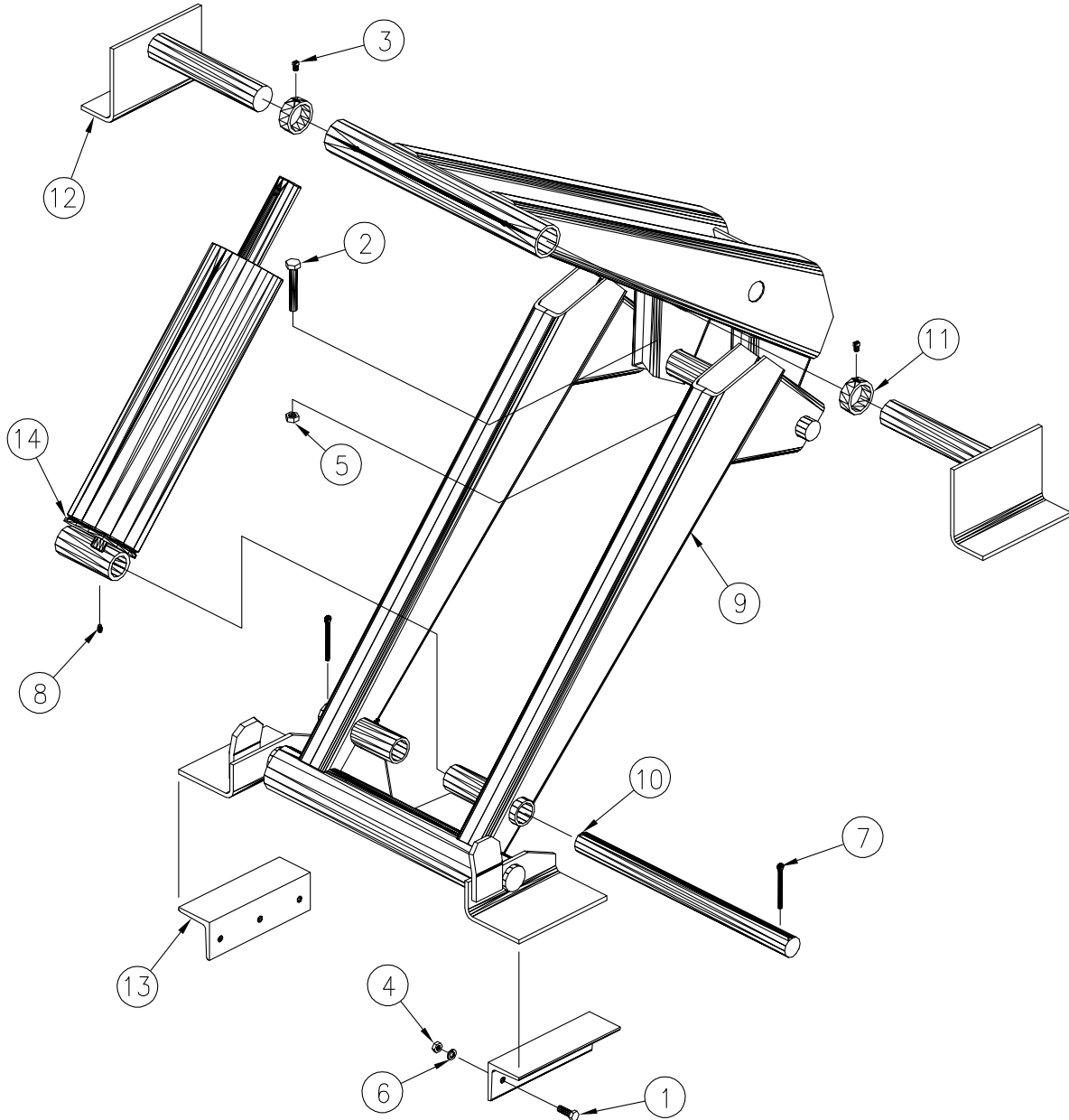

FIGURE 12 LR-28A HOIST

7	00 7959	5/16" x 3 1/2" COTTER PIN	2	14	03 2549	6" x 28" CYLINDER	1
6	00 7744	1/2" LOCK WASHER	6	13	03 0709	MOUNTING ANGLE	2
5	00 7669	5/8" HEX LOCKNUT	1	12	03 1476	LIFTING SHAFT ASSEMBLY	2
4	00 7662	1/2" HEX NUT	6	11	03 3291	LOCK COLLAR	2
3	00 7452	3/8" SET SCREW	2	10	03 0744	CYLINDER PINNING SHAFT	1
2	00 7396	5/8 x 4 1/2 HEX CAP SCREW Gr. 8 PLTD	1	9	03 1434	FRAME ASSEMBLY	1
1	00 7347	1/2 x 1 1/2 HEX CAP SCREW Gr. 5 PLTD	6	8	00 8215	GREASE FITTING 1/4" THREAD FORMING	10
ITEM	PART NUMBER	DESCRIPTION	REQ'D	ITEM	PART NUMBER	DESCRIPTION	REQ'D

LR-26B, LR-27B, LR-28A, or LR-623

Stock No. 03 5804

Page 19 of 19

